



PDM20 Smart Mini Pump Drive
User Manual

Preface

Thank you for using PDM20 series products. This manual provides you with relevant operation instructions and detailed description of parameters. Please read this manual carefully before installation, running, maintenance or inspection.

Please make sure the wiring and the pump's rotation direction is correct before use.

CONTENTS

Preface	
Notes for Safe Operation	
Chapter 1 Operation Panel	
1.1 Operation Panel Diagram.....	
1.2 Indicator Light.....	
1.3 Operation and display mode.....	
1.4 Menu Operation.....	
Chapter 2 Appearance and Wiring	
2.1 Model Description.....	
2.2 Selection table.....	
2.3Dimensions.....	
2.4 Installation Procedure Illustrations.....	
2.5Wiring Diagram of Main Circuit and Control Terminals.....	
2.6Control Terminals.....	
2.7 Wiring of Sensors.....	
Chapter 3 Quick Start	
3.1 Parameter Settings.....	
According to different types of sensors, setting the parameters as follows:.....	
3.2 Pump Rotation Direction Confirmation.....	
Chapter 4 Programming and Parameters	

4.1 Running Display Group.....

4.2 Stop Display Group.....

4.3 Pressure and Protection Function Group.....

4.4 Frequency and Auxiliary Function Group.....

4.5 Parameter Setting Procedure.....

4.6 Programming Description of Parameters.....

Chapter 5 Fault Information and Troubleshooting.....

5.1 Fault Codes Description.....

5.2 Common Faults and Actions.....

Chapter 6 Typical Application Guide.....

6.1 Single Pump Control.....

Appendix.....

Notes for Safe Operation

Read this instruction manual thoroughly before installation, operation, maintenance or inspection of the smart pump drive. In this manual, safe operation are classified as “WARNING” or “CAUTION”.

SPD: Abbreviation of smart pump drive.



Indicate a potentially dangerous situation which, if not avoided, could result in death or serious injury to personnel.



Indicate a potentially dangerous situation which, if not avoided, could result in minor or moderate injury and damage to equipment. It may also be used for warning against unsafe practices.

Even items described as ( CAUTION) may result in a vital accident in some situations. Please follow these important notes:

Before Installation



Do not install or operate any SPD that is damaged or has missing parts. Otherwise, it may result in equipment damage or harm life.

Installation



Hold the bottom of the SPD when install or move the SPD, cannot just hold the shell to prevent the injured or broken SPD.

SPD must be far away from heat source, flammable and explosive objects, and installed on metal or other nonflammable objects.

If the SPD is mounted in a protective cabinet, the cabinet need to set vents to ensure ambient temperature is below 40°C; otherwise it may be damaged because of high temperature.

Wiring



Ensure only qualified personnel to operate. Otherwise it can cause an electrical shock or damage of the SPD.

Make sure the SPD is isolated from power supply by the circuit breaker. Otherwise it may cause a fire.

Make sure that the ground terminal  is grounded correctly. Otherwise it can cause an electrical shock.

Please do not touch the main circuit terminal, and the main circuit terminals of the SPD do not contact the shell. Otherwise it may cause an electrical shock.



Before connecting, make sure that the SPD rated voltage, phase number confirm to input voltage, phase number; Otherwise it may cause fire or personal injury.

Never connect the AC input power supply to output terminals V, U, W; Otherwise the SPD will be damaged and the guarantee is invalid.

Never perform with stand voltage test of the SPD, otherwise it may cause a damage to the SPD.

The main circuit wiring of the SPD and the control loop wiring should be separated or

vertical crossed, otherwise it will make the control signal interference.

The cable connected to the main circuit terminals should be use lugswith isolated casing.

If the length of cable between the SPD and the motor is more than 50 meters, it is recommended touse a output reactor to protect the SPD and motor.

Run



Turn on the input AC power only after the front cover is put correctly; Do not open or remove the front cover when operation. Otherwise it may cause an electric shock.

If the function fault automatic reset or restart after power failure had been set, a safety measures should be taken in advance; otherwise it may cause damage or injury.

The key “RUN/STOP” may be lose efficacy because some function had been set, a separate emergency power switch can be installed in the SPD control system; otherwise it may cause damage or injury.

When the SPD is power on, the SPD terminal is still live even in stop state, do not touch, otherwise there is a risk of electric shock.



Do not use circuit breaker to control the stop or start of the SPD; Otherwise it may cause damage to the SPD.

Because the SPD speed from low to high that is in a very short time, make sure that the motor and equipment are in the permitted range to use. Otherwise it may cause damage to the equipment.

Do not touch the heat sink. Otherwise it may cause harmful burns

The factory parameters of the SPD can meet most requirements of equipment operation, if not necessary, please do not modify the parameters. Even though some equipment has special needs, only necessary parameters can be modified. Otherwise, random modifications may cause damage to the device.

Maintenance and check



When power on, do not touch the connection terminals. Otherwise it may cause an electrical shock.

Only qualified electrical engineering personnel can maintain, replace and inspect the SPD.

Wait at least 10 minutes after the power failure, or make sure that is no residual voltage before carry out maintenance and inspection, otherwise it may cause damage.



PCB board has CMOS integrated circuit, do not touch, otherwise the static electricity may damage PCB board.

Others



It is strictly forbidden to transform the SPD, otherwise it may cause casualties. After arbitrarily changing SPD, the guarantee will be invalid.

Chapter 1 Operation Panel

1.1 Operation Panel Diagram



- (1) ▲▼keys: Used to setting pressure values, switching parameters display and modifying parameters. In the “stop” status, it can be used to modify the pressure setting; In the “running” status, it can be used to switch running frequency, pressure setting and feedback pressure back and forth.
- (2) “MENU”: Pressing it for two seconds to transfer parameter mode from status display mode.
- (3)“RUN/STOP”: In status display mode without unacknowledged alarm, used as start and stop switch button between running and stop; When an alarm arise and fault code is displayed, used to acknowledge and reset alarm;In parameter setting mode, used to enter menu and confirm parameter setting.

1.2 Indicator Light

(1) **RUN**: running indicator light

Steady light: running instruction

Blinking light: sleep instruction

Steady off: stop instruction

(2) **ALAM** :fault indicator light

Drive faults or alarms

1.3 Operation and display mode

(1) **Status display mode:**

When power on the SPD, it enters the status display mode. When it stops, it displays pressure setting. Press "▲" or "▼"to modify pressure setting. When it is running, it displays current pressure, operating frequency, and setting pressure. Press the "▲" or "▼" to switch the display; press "MENU" for two seconds to enter the parameter setting mode.

(2) **Parameter setting mode:**

To view or set the parameters, as starting from status display mode, press the "MENU" for 2 seconds to enter the parameter setting mode, and then press the "RUN / STOP" starts to set parameters. After you set the parameter press twice "MENU" to exit parameter setting mode, and return to the status display mode.

(3) **The alarm display mode:**

Automatically enter this mode when a drive fault or warning arises; press the "RUN / STOP" to reset, or it can automatically restored the previous mode after the alarm is eliminated.

1.4 Menu Operation

Three-class menus are:

- ① Function group (first class)
- ② Function code setting(second class)
- ③Function code setting(third class)

Instruction: In the third class menu, pressing “MENU” or “RUN/STOP” can return to the second class menu. The difference is that pressing “RUN/STOP” first saves parameters to control board, and then returns to the second class menu and shifts to next function code automatically; pressing “MENU” returns to the second class menu directly without saving parameters and keeps staying at current function code.

Under the third class menu, only flicker bit can be modified. Revisable bit will shift automatically after 5 seconds.

Note: For parameters marked with “●”, please modify them in stopped state. Parameters marked with “◎” are actual detected and recorded values which can’t be modified.

Example: Modify P0.02 from 0 to 1

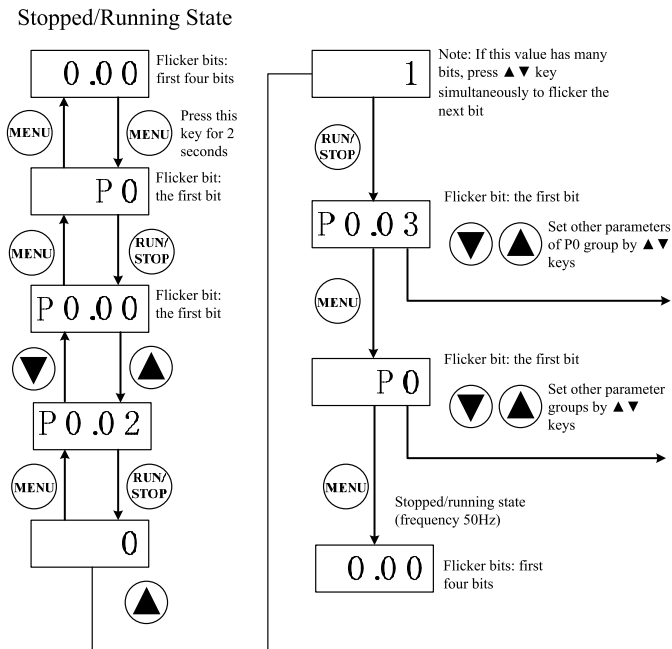

Remarks: 0.1MPa = 100kPa = 1bar = 1kgf / cm²

Chapter 2 Appearance and Wiring

2.1 Model Description

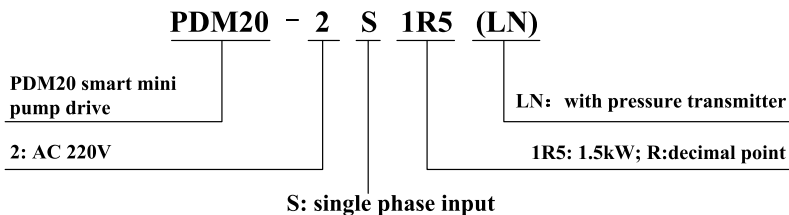

2.2 Selection table

Inverter type	Rated power	Input current	output current	Adaptation motor power	
	(kW)	(A)	(A)	(kW)	(HP)
PDM20-2SR37	0.37	5	2.5	0.37	0.5
PDM20-2SR55	0.55	7	3.5	0.55	0.75
PDM20-2SR75	0.75	9	4.5	0.75	1
PDM20-2SR90	0.9	10	5	0.9	1.2
PDM20-2S1R1	1.1	11	5.5	0.9	1.5
PDM20-2S1R5	1.5	14	7	1.5	2
PDM20-2S2R2	2.2	20	10	2.2	3

2.3 Dimensions

(Unit: mm)

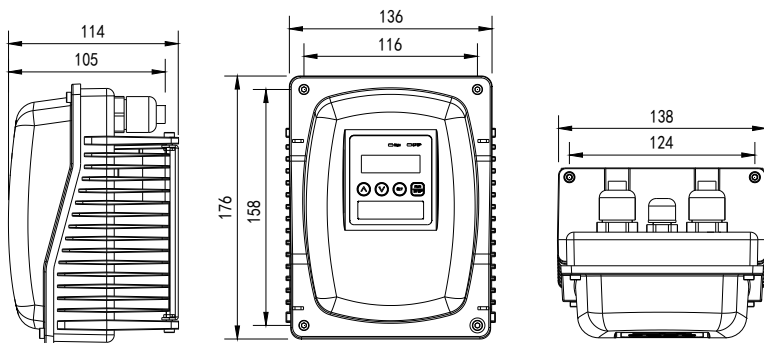

2.4 Installation Procedure Illustrations.

Step 1: Remove the iron plate at the bottom of the drive

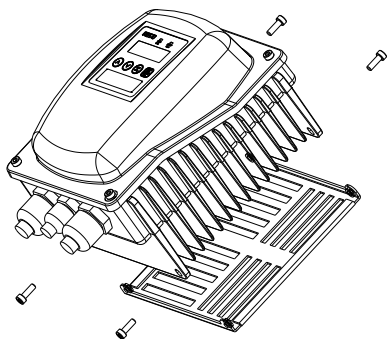

Step 2: Install the baseplate to the motor

Fasten the fixing plate
above the electrical-box
of the motor

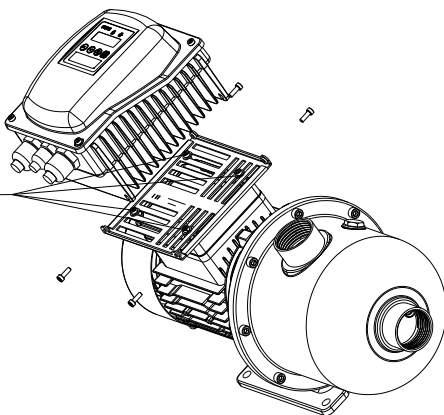

Step 3: Fix the drive on the plate

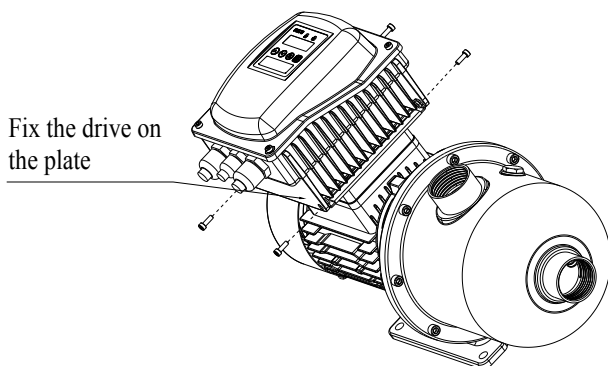

Step 4: Finish installation

Fasten the drive to the fixing board with screws

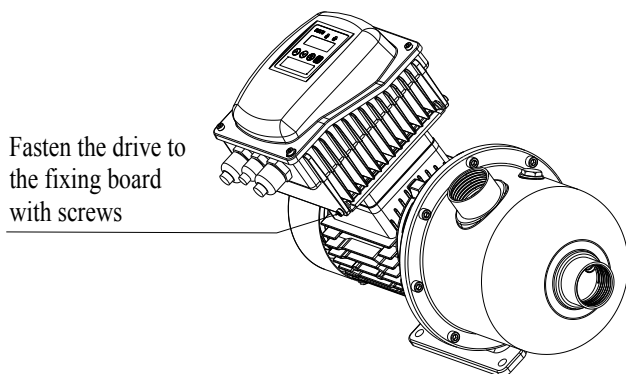

2.5 Wiring Diagram of Main Circuit and Control Terminals

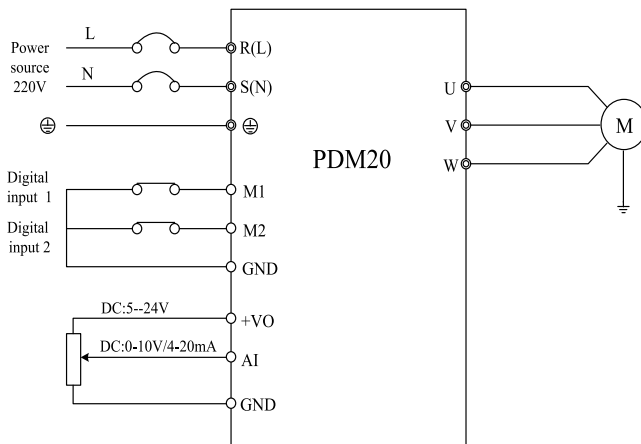

Note:

Terminals: ⊙ refers to main circuit;

Terminals: ○ control loop terminals

2.6 Control Terminals

2.6.1 Control terminals

The wiring mode of control terminals is internal terminal wiring or outer lead connection, cabled-out by waterproof connectors.



Control terminals

2.6.2 Terminal instruction

Terminal symbol	Terminal name	Technical data
M1	Multi-function input terminal 1	Enabled when connected to GND; Disabled when open
M2	Multi-function input terminal 2	Enabled when connected to GND; Disabled when open
AI	Analog input terminal 1	It is 0 ~ 10V analog voltage input terminal or 4-20mA analog current input terminal, chosen by function codes.
+Vo	Positive terminal of analog power	+5V~+24V adjustable power; Output voltage value is set by function codes.
GND	Negative terminal of analog power	Reference zero potential of +5V~+24V adjustable power

2.7 Wiring of Sensors

2.7.1 Terminal instruction

- ◆ +VO ---5 ~ 24V Power terminal for transmissible pressure gauge/pressure transmitter
- ◆ AI ---0~10V analog signal input terminal (voltage feedback type) or 4~20mA signal input terminal (current feedback type)
- ◆ GND --- 5~24V signal common terminal

2.7.2 Sensor configuration instruction

A current type pressure sensor will be used by default; output signal is 4~20mA. If use other types of sensors, please refer to the setting parameters P0.03, P0.04, P0.05 in Chapter 4.5.

2.7.3 Wiring diagram

The drive can be connected to transmissible pressure gauge and pressure transmitter. Please connect wire according to below diagrams.

(1) **Transmissible pressure gauge:** working voltage 10VDC, output 0~10VDC. Wiring method is shown as below.

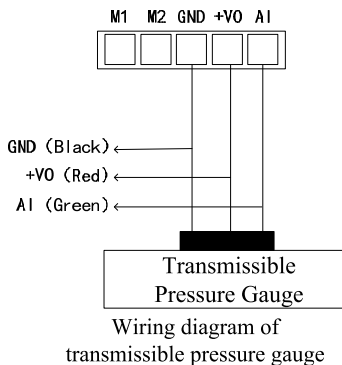

(2) **Pressure transmitter:** working voltage range 10 ~ 30V, output 4 ~ 20mA. Wiring method is shown as below.

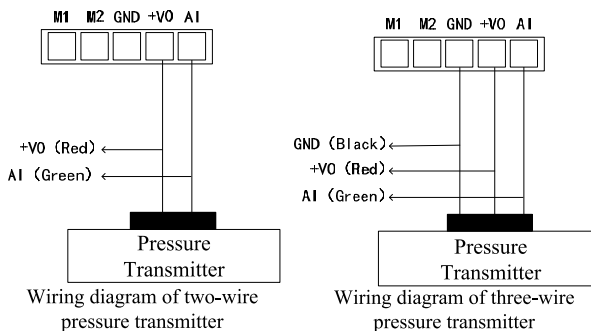

Notes: Model for PDM20-2SXXXLN products will be equipped with dedicated sensors (red line connected to terminal **+VO**; black line connected to terminal **AI**). For the wiring method of various sensors and the setting of relevant parameters, please refer to appendix.

Chapter 3 Quick Start

3.1 Parameter Settings

According to different types of sensors, setting the parameters as follows:

Sensor works as this type. Taking 10V power supply voltage, 4-20mA feedback signal, 1.6MPa pressure range, required water pressure of 4.0bar (4.0kgf/cm²) as an example, the following parameters should be set:

P0.00 = 4.0	Pressure setting
P0.03 = 16.0	Maximum range of sensor
P0.04 = 1	Sensor feedback type (pressure transmitter)
P0.05 = 10.0	Input voltage of sensor
P0.14 = 11	Auto-start, fault self-reset

3.2 Pump Rotation Direction Confirmation

Make a short-time trial operation after setting parameters to see whether the rotation direction is right or not. The direction can be changed by the following two methods:

- (1) Stop the drive and exchange arbitrary two phases of drive output power lines U, V, W.
- (2) Stop the drive and modify parameter P0.02.

Chapter 4 Programming and Parameters

Note: “○”: The parameter can be modified in both standby and operating state.

“●”: The parameter can't be modified in operating state.

“◎”: The parameter is the actual detected and recorded value which can't be modified.

4.1 Running Display Group

Press “▲”“▼” key to modify pressure setting

Display	Name	Description	Unit	Remarks
P	Current pressure	Pressure value of actual operation	bar	◎
H	Running frequency	Current running frequency	Hz	◎
d	Set pressure	Set pressure	bar	◎

4.2 Stop Display Group

Press “▲”“▼” key to modify pressure setting

Display	Name	Description	Unit	Remarks
d	Set pressure	Set pressure	bar	◎

4.3 Pressure and Protection Function Group

Function code	Description	Set range	Unit	Default	Display level	Modification level	Notes
P0.00	Pressure setting	0.0~ P0.03	bar	3.0	0	○	
P0.01	Startup pressure derivation	0.0~ P0.00	bar	0.3		○	Wakeup from standby when the pressure is lower than PID set pressure
P0.02	Running direction	0: Forward 1: Reverse		0		●	Rotation direction can be changed by modifying this parameter
P0.03	Sensor range	0.1~ 500.0	bar	10.0		○	The maximum range of sensor
P0.04	Sensor feedback type	0~1		1		○	0: Voltage feedback 1: Current feedback Set the type of sensor
P0.05	Power setting of sensor	0.0~25.0	V	25.0		○	Working voltage of sensor. Set required voltage directly
P0.06	Proportional gain	0.00~ 900.0	%	20.0		○	The bigger the parameter, the faster the pressure system responses. If it is set too high, the system will oscillate. It needs to be set according to different water supply system.
P0.07	Integral gain	0.01~ 60.00		0.90		○	Integral time of PID system

Function code	Description	Set range	Unit	Default	Display level	Modification level	Notes
P0.08	PID sleep function choices	0: Sleep invalid 1: Sleep mode 1 2: Sleep mode 2		2		○	Mode 1: Use pressure, current, frequency to judge standby Mode 2: Automatic standby
P0.09	PID sleep detection delay	0.0~3600.0	s	4.0		○	In small water consumption, if sleeping is slow or it can't sleep, make the value smaller; if it sleeps in advance or it starts and stops frequently, make the value bigger.
P0.10	PID wakeup detection delay	0.0~3600.0	s	0.0		○	PIDwakeup detection delay
P0.11	Low level hold frequency of PID sleeping detection	0.0~60.00	Hz	30.00		○	RPID runs at sleep holding frequency. After the time P0.12, PID enters sleeping mode.
P0.12	Running time of PIDLow level hold frequency	0.0~3600	s	3.0		○	Running time at low frequency in sleep mode 1
P0.13	PID sleep deviation pressure	0.0~P0.01	bar	0.1		○	When actual pressure is larger than (set pressure minus sleep deviation pressure), system starts to handle with sleep.

Function code	Description	Set range	Unit	Default	Display level	Modification level	Notes
P0.14	Automatically start self-reset at power on	00~11		10		○	Ones: auto-start choices 0: OFF 1: ON Tens: fault self-reset choices 0: OFF 1: ON By default, self-reset is ON and auto-start is OFF.
P0.15	Self-starting delay at power on	0.0~100.0	s	5.0		○	Delay time before auto-start at power on
P0.16	Antifreeze	0: OFF 1: ON		0		○	Self anti-freezing function of pump
P0.17	Anti-freezing running frequency	0.0~60.00	Hz	8.00	1	○	
P0.18	Anti-freezing running time	0~60	s	60	1	○	
P0.19	Anti-freezing running cycle	60~9999	s	300	1	○	When it is set as 0, it keeps running at anti-freezing running frequency
P0.20	Water leakage coefficient	0.0~100.0		2.0		○	The bigger the water leakage, the bigger the coefficient.
P0.21	Set value of high pressure alarm	0.0~P0.03	bar	8.0		○	When feedback pressure is bigger than or equal to the set value, after the delay of P0.22, it alarms and stops.
P0.22	Detection time of high pressure alarm	0.0~200.0	s	3.0			

Function code	Description	Set range	Unit	Default	Display level	Modification level	Notes
P0.23	Set value of low pressure alarm	0.0~P0.21	bar	0.0		○	When feedback pressure is smaller than the set value, after the delay of P0.24, it alarms and stops. This function is invalid when it is set to 0.
P0.24	Detection time of low pressure alarm	0.0~200.0	s	3.0		○	
P0.25	Water shortage protection	00~11		10	1	○	Ones: judge water shortage according to frequency, current 0: OFF 1: ON Tens: judge by pressure 0: OFF 1: ON By default, pressure judgment is ON.
P0.26	Water shortage fault detection threshold	0.0~P0.00	bar	0.5	1	○	It judges water shortage only when feedback pressure is smaller than the set value.
P0.27	Water shortage protection detection frequency	0~60.00	Hz	45.00	1	○	It is valid when P0.25 =01. Comparison frequency of water shortage judgment. When running frequency is larger than this frequency, it starts to judge water shortage.

Function code	Description	Set range	Unit	Default	Display level	Modification level	Notes
P0.28	Current percentage of water shortage protection detection	0.0~100.0	%	40.0	1	○	It is valid only when P0.25=01. Percentage of motor rated current. When running current is smaller than this current, it judges as water shortage.
P0.29	Water shortage protection detection time	0~900.0	s	20.0		○	
P0.30	Self-restarting delay of water shortage protection	0~9999	min	15	1	○	If it is set to be 0, use pressure to self-reset water shortage.
P0.31	Self-sleep rate	1~30		3	1	○	Increase this value when the system can't sleep.
P0.32	Inflow detection pressure	0.0~P0.00	bar	1.0	1	○	After inflow pressure is larger than detection pressure time (P0.33), water shortage fault is automatically reset.
P0.33	Inflow detection time	0.0~100.0	s	1.0	1	○	
P0.34	Lower limit of AI	0.0~P0.35	V/mA	4.00		○	
P0.35	Upper limit of AI	P0.34~20.00	V/mA	20.00		○	
P0.36	Acceleration time	0.1~3600	s	5.0		○	
P0.37	Deceleration time	0.1~3600	s	3.0		○	

Function code	Description	Set range	Unit	Default	Display level	Modification level	Notes
P0.38	Parameter initialization	0~2		0	0	●	0: No operation 1: Reset to factory defaults 2: Clear fault records
P0.39	Parameter lock	0~1		0		○	If it is set to be 1, P1 group parameters will be hidden.

Function code	Description	Set range	Unit	Default	Display level	Modification level	Notes
P0.40	Current fault type	0~29					0: No fault 1: Inverter unit protection (E001) 2: Over current in acceleration (E002) 3: Over current in deceleration (E003) 4: Over current at constant speed (E004) 5: Over voltage in acceleration (E005) 6: Over voltage in deceleration (E006) 7: Over voltage at constant speed (E007) 8: Hardware overvoltage (E008) 9: Under voltage fault (E009) 10: SPD overload(E010) 11: Motor overload (E011) 12: Reserved 13: Output phase loss (E013) 14: Radiator overheating (E014) 15: External water shortage (E015) 16~17: Reserved 18: Current detection fault (E018) 19~21: Reserved 22: EEPROM fault(E022)

Function code	Description	Set range	Unit	Default	Display level	Modification level	Notes
P0.40	Current fault type	0~29				○	23: Over torque fault (E023) 24: Broken line fault of PID feedback (E024) 25: Running time reaches. (E025) 26: Reserved(E026) 27: Water shortage alarm(E027) 28: High pressure alarm(E028) 29: Low pressure alarm(E029)
P0.41	Radiator temperature	0~100	℃	0	1	◎	
P0.42	Software version				0	◎	
P0.43	Frequency command choices	0~8		8		●	0: Digital setting 1~7: Reserved 8: Water supply PID

4.4 Frequency and Auxiliary Function Group

Function code	Description	Set range	Unit	Default	Display level	Modification level	Notes
P1.00	Pressure setting	0.0~P1.03	bar	3.0	0	○	Same as P0.00
P1.01	Start pressure deviation	0.0~P1.00	bar	0.3		○	Same as P0.01
P1.02	Running direction choices	0: Forward 1: Reverse		0		●	Same as P0.02

Function code	Description	Set range	Unit	Default	Display level	Modification level	Notes
P1.03	Sensor range	0.1~500.0	bar	10		○	Same as P0.03
P1.04	Sensor feedback type	0: Voltage feedback 1: Current feedback		1		○	Same as P0.04
P1.05	power setting of sensor	0.0~25.0	V	25.0		○	Same as P0.05
P1.06	Upper limit of running frequency	P1.07~60.00	Hz	50.00		○	
P1.07	Lower limit of running frequency	0.0~P1.06	Hz	0.00		○	
P1.08	Action choices when running frequency is lower than lower limit frequency	0~2		2		○	0: Run at lower limit frequency 1: Stop 2: Standby
P1.09	Carrier frequency setting	1.0~15.0	kHz	Set by model		○	The value can be adjusted properly to adjust motor noise

Function code	Description	Set range	Unit	Default	Display level	Modification level	Notes
P1.10	Feedback broken line detection value	0~1.00	V	0.10			When running frequency reaches MAX. running frequency, after PID feedback broken line detection time (5s by default), if PID feedback value is still smaller than PID feedback broken line detection value, it will report feedback broken line fault
P1.11	Feedback broken line detection time	0~3600.0	s	5.0			The function is invalid when it is set as 0
P1.12	Motor rated power	0.2~4.0	kW	Set by model		●	Set according to motor nameplate
P1.13	Motor rated frequency	10~60.00	Hz	Set by model		●	Set according to motor nameplate
P1.14	Motor rated speed	0~36000	rpm	Set by model		●	Set according to motor nameplate
P1.15	Motor rated voltage	0~480	V	220		●	Set according to motor nameplate
P1.16	Motor rated current	0.1~400.0	A	Set by model		●	Set according to motor nameplate
P1.17	User password	0000 ~ 9999			1	○	
P1.18	Function choices of M1 terminal	0~25		1	1	●	0: No function 1: Run 2~6: Reserved

Function code	Description	Set range	Unit	Default	Display level	Modification level	Notes
P1.19	Function choices of M2 terminal			9	1	●	7: Fault reset 8: Pause 9: External fault input (water shortage) 10~24: Reserved 25: PID control pause
P1.20	VDI function choices					●	
P1.33	PWM Mode	0~2		0	1	○	
P1.34	Start/stop signal choices	0~1		0	1	○	0: Start/stop by keyboard 1: Start/stop by terminals

4.5 Parameter Setting Procedure

Taking the commonly used parameters of P0.00 - P0.05 as an example, the parameters setting steps are as follows.

Set P0.00 (Pressure setting)

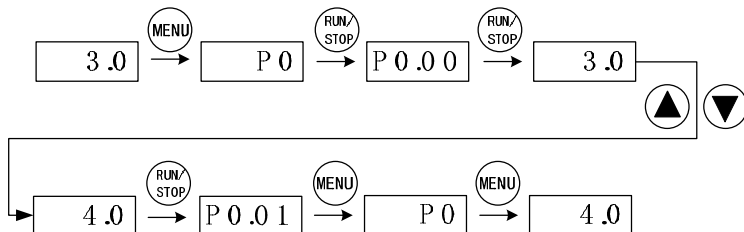

Notes: Pressing “▲” or “▼” to modify the setting pressure as 4.0 in the stop displayed status

Set P0.01 (Startup pressure derivation)

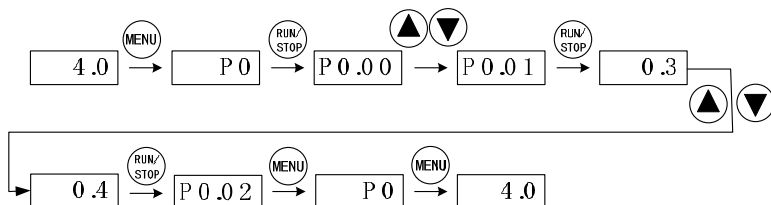

Set P0.02 (Running direction)

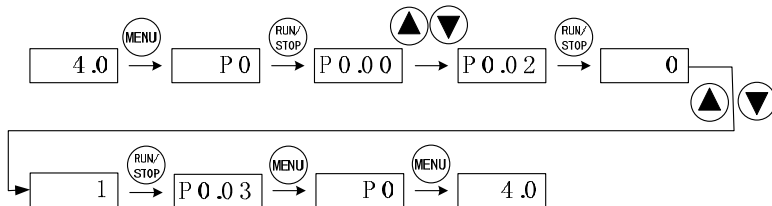

Set P0.03 (Sensor range)

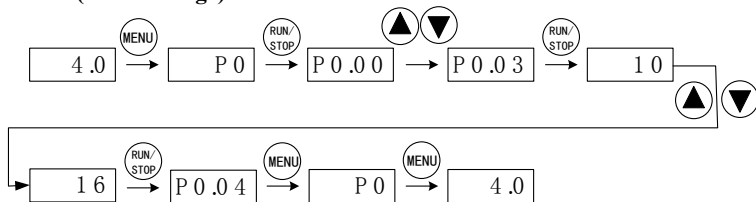

Set P0.04 (Sensor feedback type)

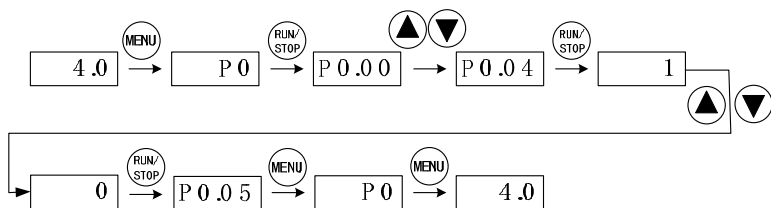

Set P0.05 (Power setting of sensor)

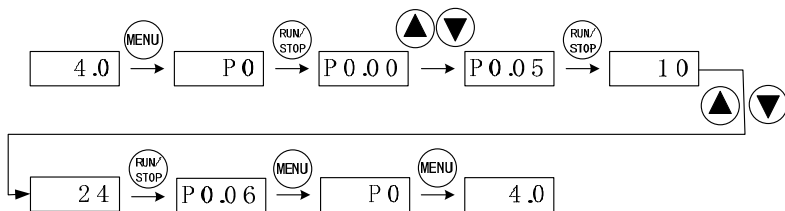

4.6 Programming Description of Parameters

P0.00	Pressure setting	0.0~P0.03	bar	3.0	
P0.03	Sensor range	0.0~200.0	bar	10.0	The maximum range of sensor
P0.04	Sensor feedback type	0: Voltage feedback 1: Current feedback		1	
P0.05	Power setting of sensor	0.0~24.0	V	10.0	

P0.03 is the range of the sensor. Common range is 1MPa, namely 10.0bar.

P0.00 is the pressure value of the pipe network. If P0.00=3.0bar, after the smart pump drive is started, the pressure of the pipe network keeps constant at 3.0 bar.

General sensor is in current type. The wiring method of SPD is similar to pressure transmitter, connected to AI terminal as pressure feedback: if voltage sensor is use, please modify P0.04 to 0. The wiring method of SPD is similar to transmissible pressure gauge, connected to AI terminal as pressure feedback.

Note: because working voltage of sensor is different, before using, set working power source of the sensor by P0.05; besides, make sure test result is precise. Set range of the sensor P0.03 according to sensor parameters.

P0.01	Start pressure deviation	0.0~P0.00	bar	0.3	The value that is lower than PID set pressure
P0.10	PID wakeup detection delay	0.0~120.0	s	1.0	PID wakeup detection delay

When feedback value is smaller than or equal to set pressure minus PID start pressure (P0.00-P0.01) , and it holds the state in P0.10 set time, PID adjustment will be restarted. For example, when P0.00=3, P0.01=0.3, P0.10=5.0, if feedback value is smaller than or equal to 2.7, and the time is longer than 5s, PID adjustment will be restarted. Once it is larger than 2.7, the time will recount.

P0.02	Running direction of motor	0: Forward 1: Reverse		0	Modify this parameter to change running direction
-------	----------------------------	--------------------------	--	---	---

In initial use, confirm the rotation direction of motor. Exchange arbitrary two lines of output power line U, V, W of the SPD or modify parameter P0.02 to change the rotation direction of the motor.

P0.06	Proportional gain	0.0~100.0	%	20	The larger the parameter, the faster the response speed of the pressure system. However, when it is set too big, the system will oscillate. Adjust it according to different water supply system.
-------	-------------------	-----------	---	----	---

Adjustment method:

If factory parameters can't meet demands, adjust parameters finely. First increase proportional gain to make sure that the system will not oscillate.

Note: improper parameter setting of P0.06 will cause huge speed overshoot, and even over voltage fault in overshoot back.

P0.08	PID sleep choices	0~2		2	0: Sleep invalid 1: Sleep mode 1 2: Sleep mode 2
P0.09	PID sleep detection delay	0.0~120.0	s	1.0	In small water consumption, if sleeping is slow or it can't sleep, make the value smaller; if it sleeps in advance or it starts and stops frequently, make the value bigger.
P0.10	PID wakeup detection delay	0.0~120.0	s	1.0	PID wakeup detection delay
P0.11	PID sleep low level hold frequency	0.00~60.00	Hz	35.00	PID runs at sleep low level hold frequency. After the time of P0.12, PID sleeps.
P0.12	Running time at PID low level hold frequency	0.00~3600	s	3.0	
P0.13	PID sleep deviation pressure	0.0~P0.01	bar	0.1	If feedback pressure is in sleep deviation range, start sleeping treatment.

After selecting sleep mode 1 by parameter P0.08, the SPD will detect whether feedback pressure is higher than set pressure. If yes, the SPD will start sleep detection. After PID sleep detection delay set by P0.09, if feedback pressure is still higher than set pressure, SPD will decrease output frequency gradually to sleep detection low level hold frequency set by P0.11. After sleep detection low level hold frequency waiting time, if feedback pressure is still higher than set pressure, the SPD decreases output frequency to 0Hz and enter standby. If in above process, feedback pressure is lower than set pressure, the SPD will judge as invalid sleep detection and come back to PID adjustment status.

When sleep mode 2 is selected, the system will try to sleep according to water consumption condition automatically.

After the SPD enters standby, if feedback pressure is lower than PID sleep threshold, SPD will start wakeup detection. After PID wakeup detection delay set by P0.10, if feedback pressure is still lower than wakeup pressure threshold, wakeup is successful and SPD comes back to PID adjustment status; else, wakeup fails. Too high PID sleep threshold may cause frequent start and stop of the SPD. Too low PID sleep threshold may cause deficient pressure.

Notes: sleep holding frequency of different water supply system is different. When there is no water outside and the water tap is turned off, but the pump is still running, increase P0.11 to sleep holding frequency.

P0.14	Automatically start self-reset at power on	Ones: Auto-start choices 0: OFF 1: ON Tens: Fault self-reset choices 0: OFF 1: ON		10	By default, self-reset is ON and auto-start is OFF.
P0.15	Auto-start delay at power on	0.0~100.0	s	5.0	Delay time before auto-start at power on

If you hope that the SPD can start automatically after time delay set by P0.15 at power on, after setting all parameters, make P0.14 = 11 to enable auto-start function of the SPD. Every time at power on or fault reset, it will start automatically.

P0.16	Antifreeze	0: OFF 1: ON		0	Self anti-freezing function of pump
P0.17	Anti-freezing running frequency	0.0~60.00	Hz	8.00	
P0.18	Anti-freezing running time	0~9999	s	60	
P0.19	Anti-freezing running interval	0~9999	s	300	When it is set as 0, it keeps running at anti-freezing running frequency

Set P0.16=1 to enable anti-freezing function. The SPD will adjust the running frequency of pump according to current status after it is started.

Note:

- ① Pump auto-adjusting given frequency is prior to anti-freezing frequency.
- ② Anti-freezing frequency can't be set to high. It should be set as the frequency that can just drive the pump but can't supply pressure.

P0.20	Water leakage coefficient	0.0~100.0		2.0	The bigger the water leakage, the bigger the coefficient.
-------	---------------------------	-----------	--	-----	---

In no water consumption, because of water leakage of pipe network, the SPD can't sleep and stop. It starts and stops frequently. To solve the water leakage problem of pipe network, modify the value of P0.20 according to water leakage. The bigger the water leakage, the bigger the coefficient.

P0.21	Set value of high pressure alarm	0.0~P0.03	bar	8.0	When feedback pressure is bigger than or equal to the set value, after the delay of P0.22, it alarms and stops.
P0.22	Detection time of high pressure alarm	0.0~200.0	s	3.0	
P0.23	Set value of low pressure alarm	0.0~P0.21	bar	0.0	When feedback pressure is smaller than the set value, after the delay of P0.24, it alarms and stops. This function is invalid when it is set to 0.
P0.24	Detection time of low pressure alarm	0.0~200.0	s	3.0	

The SPD will compare P0.21 and P0.23 according pipe network pressure fed back by sensor. If pressure is abnormal, it will stop and alarm automatically to protect pipe network system.

P0.25	Water shortage protection	00~11		10	Ones: judge water shortage according to frequency, current 0:OFF 1:ON Tens: judge by pressure 0:OFF 1:ON
P0.26	Water shortage fault detection threshold	0.0~P0.00	bar	0.5	It judges water shortage only when feedback pressure is smaller than the set value.
P0.27	Water shortage protection detection frequency	0~60.00	Hz	45.00	It is valid when P0.25 = 01. Comparison frequency of water shortage judgment.
P0.28	Current percentage of water shortage protection detection	80~300.0	%	150.0	It is valid only when P0.25=01. Percentage of motor rated current.
P0.29	Water shortage protection detection time	0~900.0	s	20.0	

P0.30	Self-restarting delay of water shortage protection	0~9999	min	15	If it is set to be 0, use pressure to self-reset water shortage.
-------	--	--------	-----	----	--

Following methods can realize water shortage protection by default:

- (1) The switch of water shortage protection is turned on (P0.25=1x) ;
- (2) The feedback pressure is less than allowed threshold value of water shortage detection(feedback pressure<P0.26);
- (3) The current running frequency is no less than water shortage protection detection frequency (running frequency>=P0.27) ;
- (4) When (1) - (3) are satisfied, timing starts. When the time meeting the condition exceeds abnormal pressure alarm delay time (delay time>P0.29), water shortage fault will be reported. When either condition is not satisfied during timing, timing recounts.

When water shortage fault is reported, after the time set by P0.30, the drive will reset. By setting the next following parameters:

P0.32	Inflow detection pressure	0.0~P0.00	bar	1.0	
P0.33	Inflow detection time	0.0~100.0	s	1.0	

Use inflow detection pressure to reset water shortage faults directly.

Note:When judge water shortage according to pressure, because the working condition of each drive is different such as range of load size, only setting the value of P0.28 reasonably according to site conditions can it make correct judgment to water shortage.

Setting method: Run the drive. When running frequency reaches maximum frequency, turn off inlet and record the output current displayed on the drive. Divide this current by P1.16 (the rated current of the motor) to get a percentage. Make the value of P0.28 a little higher than 5-10 percentage points of the percentage. Too high value of P0.28 will lead to false water shortage report in normal operation. Water shortage protection will not work effectively with too low value of P0.28.

P0.34	Lower limit of AI input signal	0.0~ P0.35	V/mA	4.00	Used to correct lower limit of AI signal
P0.35	Upper limit of AI input signal	P0.34~ 20	V/mA	20.00	Used to correct upper limit of AI signal

If you find there is some deviation between sensor feedback pressure and feedback pressure displayed on SPD, adjust above parameter to correct the sensor.

Note: the unit of current sensor is 4~20mA; that of voltage sensor is 0~10V.

P0.36	Acceleration time	0.1~3600	s	5.0	
P0.37	Deceleration time	0.1~3600	s	3.0	

Acceleration/deceleration time setting of the pump's motor.

P0.38	Parameter initialization	0~2		0	
-------	--------------------------	-----	--	---	--

When P0.38 is set as 1, restore factory defaults.

P0.39	Parameter lock function	0~1		0	
-------	-------------------------	-----	--	---	--

After setting parameters, if you don't want them to be modified by misoperation, make P0.39= 1. At this time, parameters can only be monitored, but not be modified. Only when P0.39 is modified to 0, can parameters be modified.

P0.40	Current fault type	0~29			
-------	--------------------	------	--	--	--

Record fault type of the SPD. 0 means no fault. 1~29 refers to E001~E029. For more details, please refer to fault inspection and troubleshooting chapter.

P1.34	Start/stop signal choices	0~1		0	0: Start/stop by keyboard 1: Start/stop by terminals
P0.43	Frequency source choices	0~8		8	0: Digital setting 1~7: Reserved 8: Water supply PID

Each SPD can choose different start/stop modes and frequency sources.

P1 group parameters have the same meaning as P0 group. Please refer to P0 group for more details.

P1.06	Upper limit frequency	P1.07~60.0		Hz	50.00	
P1.07	Lower limit frequency	0.00~P1.06		Hz	0.00	
P1.08	Action choices when running frequency is lower than lower limit frequency	0: Run at lower limit frequency 1: Stop 2: Standby			2	

P1.06 limits the maximum working frequency of SPD.

Use P1.08 to choose running status of SPD when running frequency is lower than lower limit frequency. To prevent motor from being in low speed operation for a long time, you can use this parameter to stop it.

If use a 60Hz pump, please set parameters according to the following steps.

Step 1: Set the parameter P1.06 (Upper limit frequency) to 60

Step 2: Set the parameter P1.13 (Motor rated frequency) to 60

P1.09	Carrier frequency setting	1.0~15.0	kHz	Set according to models	
-------	---------------------------	----------	-----	-------------------------	--

Use this parameter to adjust carrier frequency of SPD. You can decrease motor noise by adjusting carrier frequency, avoid point of resonance, decrease leakage current of wires to ground and decrease interference of SPD.

When carrier frequency is high, motor loss decreases, temperature rising of motor is small, but SPD loss increases, temperature rising of SPD increases and interference increases.

P1.10	Feedback broken line detection value	0.0~1.00	V	0.10	
P1.11	Feedback broken line detection time	0.0~3600	s	5.0	

Feedback broken line detection value: the detection value is relative to input signal voltage. System keeps detecting PID feedback value. When feedback value is smaller than or equal to feedback broken line detection, system starts detection timing. When detection timing exceeds feedback broken line detection time, system will report PID feedback broken line fault.

P1.12	Motor rated power	0~4.0	kW	Set according to models	
P1.13	Motor rated frequency	0.01~60.00	Hz	Set according to models	
P1.14	Motor rated speed	0~36000	rpm	Set according to models	
P1.15	Motor rated voltage	0~280	V	Set according to models	
P1.16	Motor rated current	0.1~40	A	Set according to models	

Please set according to parameters of the motor nameplate.

To guarantee control performance, please configure motor according to standard adaptive motor of drives. If there is big difference between motor power and standard adaptive motor, control performance of drives will decrease obviously.

Chapter 5 Fault Information and Troubleshooting

5.1 Fault Codes Description

Fault code	Fault type	Possible reasons	Solution
E001	Invert cells fault	1. Too fast acceleration	1. Increase acceleration time
		2. IGBT inside broken	2. Seek for support
		3. Malfunction caused by interference	3. Check whether peripheral equipments have strong interference source
		4. .Sound grounding or not	4. Check grounding line
E002	Over current in accelerated running	1. Too fast acceleration	1. Increase acceleration time
		2. Too low grid voltage	2. Check input power
		3. The power of the SPD is too low	3. Use bigger power SPD
E003	Over current in decelerated running	1. Too fast deceleration	1. Increase deceleration time
		2. The inertia torque of load is too big.	2. Add proper dynamic braking modules
		3. The power of the SPD is too low	3. Increase power of the SPD
E004	Over current in constant speed running	1. Saltation or abnormality happens to load	1. Check the load or decrease the saltation of the load
		2. The grid voltage is too low	2. Check input power supply

Fault code	Fault type	Possible reasons	Solution
		3. The power of the SPD is too low	3. Use bigger power SPD
E005	Over voltage in accelerated running	1. The input voltage is abnormal	1. Check input power supply
		2. Restart rotating motor after momentary outages	2. Avoid restarting after it is stopped
E006	Over voltage in decelerated running	1. Too fast deceleration	1. Increase acceleration time
		2. The inertia of load is too big	2. Increase dynamic braking modules
		3. The input voltage is abnormal.	3. Check input power
E007	Over voltage in constant speed running	1. Abnormal changes happen to input voltage	1. Install input reactor
		2. The inertia of load is too big	2. Add proper dynamic braking modules
E008	Hardware over voltage	1. The input voltage is abnormal	1. Check input power supply
		2. Too fast deceleration	2. Increase deceleration time
		3. The inertia of load is too big	3. Increase dynamic braking modules
E009	Bus under voltage	1. The grid voltage is too low	1. Check grid input power supply
E010	Controller overload	1. Too fast acceleration	1. Increase acceleration time
		2. Restart rotating motor	2. Avoid restarting after it is stopped
		3. The grid voltage is too low	3. Check grid voltage

Fault code	Fault type	Possible reasons	Solution
		4. Overload	4. Use bigger power SPD
E011	Motor overload	1. The grid voltage is too low	1. Check grid voltage
		2. Wrong setting to motor rated current	2. Reset motor rated current
		3. Motor stall or big changes to load	3. Check the load and adjust torque lifting capacity
		4. Motor is too small	4. Use proper motor
E013	Output phase loss	U,V,W phase loss output(or the three phases of load is not symmetrical)	1. Check output wiring
			2. Check motor and cable
E014	Module overheating	1. Instant over current of SPD	1. Refer to over current solutions
		2. Output three phases have interphase or ground is short circuit	2. Re-wiring
		3. Air passage block or fan broken	3. Dredge air passage or change fan
		4. The environmental temperature is too high	4. Decrease environmental temperature
		5. SPD wire or plugins loose	5. Check and re-connect
		6. Power circuit irregularity	6. Seek for service

Fault code	Fault type	Possible reasons	Solution
		8. Control board exception	
E015	External water shortage	Water shortage is detected	Check whether water is deficient.
E018	Fault of current detection circuits	1. Poor contact of control board connector	1. Check connector and re-plug
		2. Power circuit irregularity	2. Seek for service
		3. Damage to hall devices	
		4. Exception of amplifying circuit	
E022	EEPROM read write faults	1. Read write of control parameter goes wrong	1. Press RUN/STOP key to reset
		2. EEPROM broken	2. Seek for service
E023	Torque rich	1. Too fast acceleration	1. Increase acceleration time
		2. Restart rotating motor	2. Avoid restart rotation motor
		3. Grid voltage is too low	3. Check grid voltage
		4. Load is too heavy	4. Use big power SPD
E024	PID feedback broken line fault	1. Sensor broken line or poor contact	1. Check the installation and wiring of sensor
		2. Broken line detection time is too short	2. Increase broken line detection time
		3. The sensor is broken or the system has no feedback signal	3. Change sensor

Fault code	Fault type	Possible reasons	Solution
E025	Running time reaches set time	1. Running time reaches set time	1. Seek for service
E026	Reserved	Reserved	Reserved
E027	Water shortage alarm	1. Water pressure/level exception	1. Check whether the pressure of inlet is abnormal or not
		2. Sensor broken line or poor contact. System has no feedback signal	2. Check the installation and wiring of sensor
		3. Water shortage alarm detection time is too short (P0.29)	3. Check relevant parameter settings
		4. Water shortage protection frequency is too low(P0.27)	
		5. Water shortage protection detection current is too low(P0.28)	
E028	High pressure alarm	1. Feedback signal of sensor exception	1. Check the wiring of sensor
		2. High pressure alarm value adjustment is too low (P0.21)	2. Check relative parameter settings
		3. Alarm detection time adjustment is too short (P0.22)	
E029	Low pressure alarm	1. Low pressure alarm value is set too high (P0.23)	1. Modify parameters
		2. Sensor broken line or poor contact. System has no feedback signal	2. Check the sensor

Fault code	Fault type	Possible reasons	Solution
		3. Sensor type is inconsistent with actual situation	

5.2 Common Faults and Actions

The following faults may happen in use. For brief fault analysis, please refer to the following methods.

5.2.1 No display at power on

- (1) Check whether the input power is consistent with the nominal voltage of the drive with multimeter.
- (2) Check whether the three-phase rectifier bridge is intact. If the rectifier bridge is broken down, please request service.

5.2.2 The power air switch trips off at power on.

- (1) Check whether there is short circuit or ground connection between input power. If yes, please eliminate it.
- (2) Check whether the rectifier bridge has been broken down. If yes, please request service.

5.2.3 The motor doesn't rotate after the SPD runs.

- (1) Check whether there is balanced three-phase output among U, V,W. If yes, check whether the motor is broken or blocked. If no, please confirm whether the motor parameters are set correctly.
- (2) If there is output but the three-phase power is not balanced, please request service.
- (3) If there is no output voltage, please request service.

5.2.4 SPD shows normally at power on but the power air switch trips off after running.

- (1) Check whether short circuit occurs between output modules interval. If yes, please request service.

(2) Check if there is short circuit or ground connection between motor leads. If yes, please eliminate it.

(3) If switch stripping off occurs occasionally and the distance between motor and inverter is far, consider to add output AC reactor.

5.2.5 It doesn't stop in no water use.

(1) Check whether the feedback pressure displayed on the SPD board is no less than set pressure. If the feedback pressure is less than set pressure, please check whether the range of the pressure sensor is set correctly, whether the pump rotates reversely, whether there is air and whether the inlet is blocked by sundries.

(2) If the feedback pressure is no less than set pressure, please decrease the set value of P0.09 and increase P0.11.

(3) If feedback pressure changes nearby set value, stop the SPD manually and see whether the pressure decreases. If yes, check valve needs to be changed.

5.2.6 It can't sleep in small amount of water use or leakage

(1) If it can't sleep or the sleep time is too long, decrease P0.09 and increase P0.11, If it is still not effective, increase P0.31.

(2) If it sleeps in advance, first increase P0.09. If it is still not effective, decrease P0.20.

(3) If it starts and stops frequently, first increase P0.09. If it is not effective, increase P0.20. If it is still not effective, increase P0.01.

5.2.7 It can't stop to make protection in water shortage.

(1) Water shortage protection switch P0.25 is not enabled.

(2) The threshold value of water shortage detection P0.26 is set too low.

(3) The current percentage of water shortage detection P0.28 is set too low.

Chapter 6 Typical Application Guide

6.1 Single Pump Control

Condition	Requirement	Parameter setting
Pipe network pressure	3.0bar	P0.00 = 3.0
Water shortage protection mode	Switching value sensor is installed at inlet.	Input by external terminals

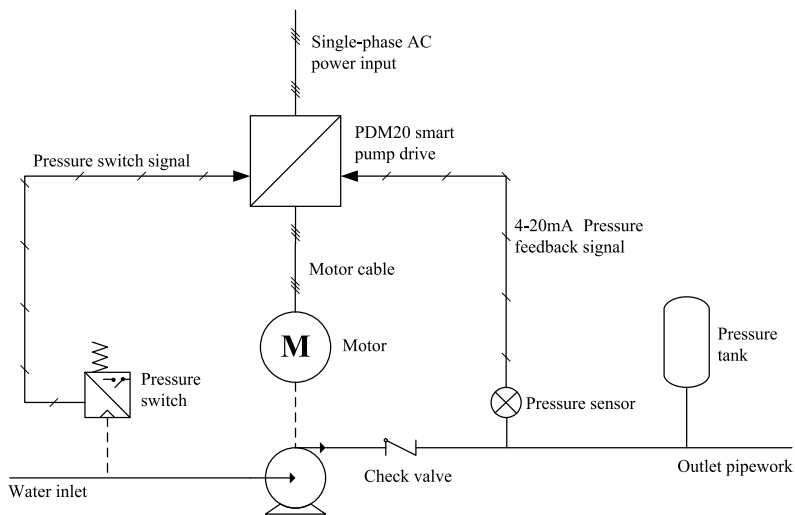

Appendix

Types of pressure sensor wiring diagram

1. Transmissible pressure gauge wiring diagram

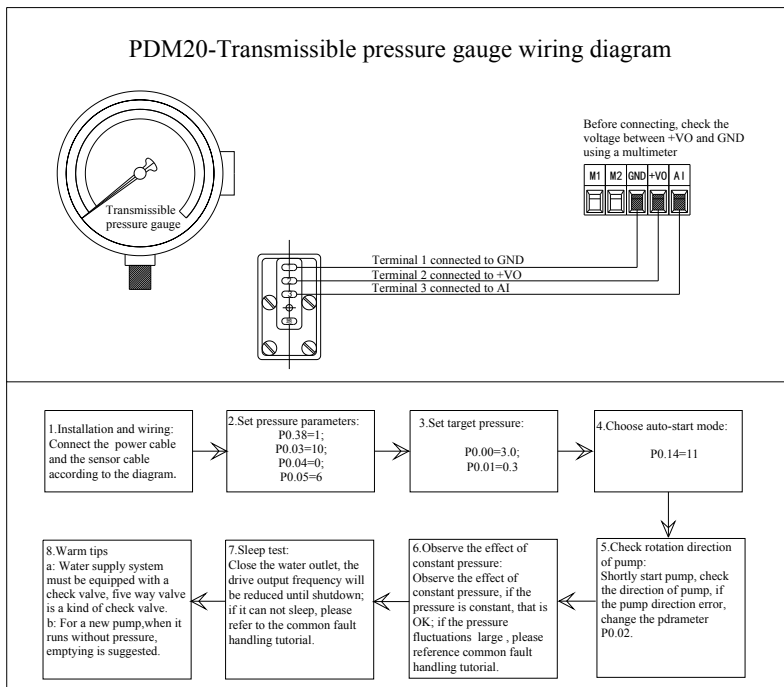

2. Three wire 10V sensor wiring diagram

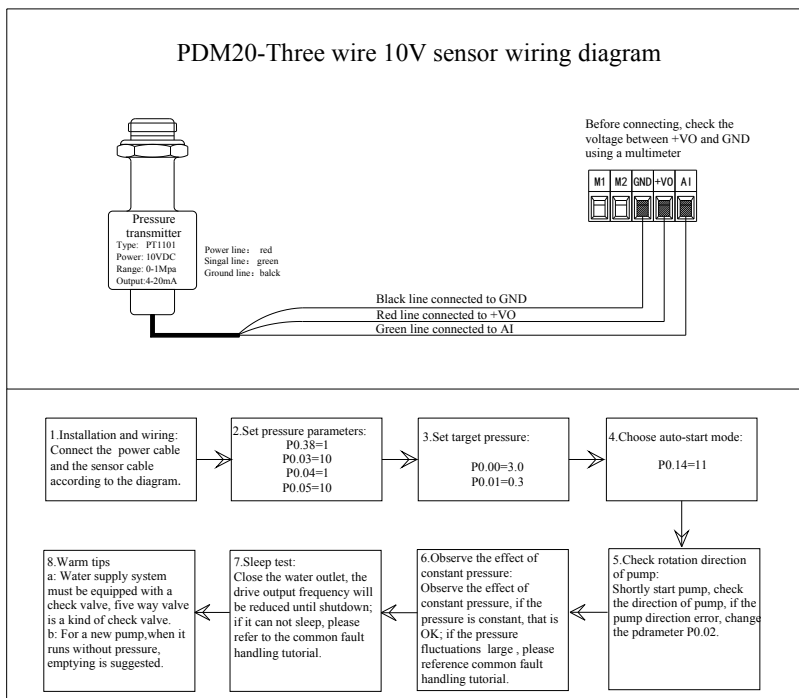

3. Two wire sensor wiring diagram

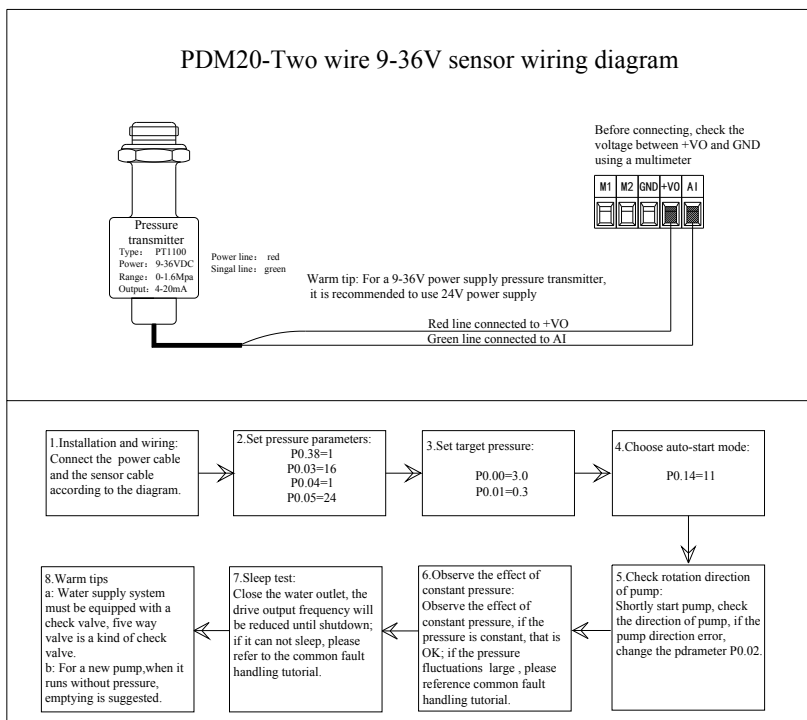

4. Three wire 24V sensor wiring diagram

