



VM1000B AC Drive

User Manual

Preface

Thank you for choosing VM1000B Series AC Drive.

This user manual introduces the technical specifications, installation instructions, functions and performance of VM1000B Series AC Drive properly. Please read this user manual carefully before carrying out works such as installation, commissioning, maintenance, etc.

You are specially warned to read and understand safety precaution items of this manual before using this product, and to ensure that relevant electrical installation testers' professional qualification shall be in line with the provisions of the labor supervision department, and the electrical and environmental conditions for product use shall be in conformity with relevant national standards.

Be sure to verify that the wiring is correct before powering on the product. Before starting the product, it is necessary to debug to ensure correct motor rotating direction.

Please check for the latest version at www.saj-electric.com.

Guangzhou Sanjing Electric Co., Ltd.

Contents

PREFACE	- 1 -
SAFETY PRECAUTIONS	- 3 -
CHAPTER 1 PRODUCT INFORMATION	- 6 -
1.1 TECHNICAL SPECIFICATIONS.....	- 6 -
1.2 PRODUCT NAMEPLATE.....	- 9 -
1.3 MODEL DESCRIPTION	- 9 -
1.4 PRODUCT MODEL	- 10 -
CHAPTER 2 INSTALLATION	- 12 -
2.1 OVERALL STRUCTURAL DRAWING (UNIT: MM)	- 12 -
2.2 KEYPAD AND INSTALLATION.....	- 15 -
2.3 MAIN CIRCUIT CONNECTION	- 16 -
2.4 CONTROL CIRCUIT CONNECTION.....	- 17 -
CHAPTER 3 DISPLAY AND OPERATION	- 21 -
3.1 KEYPAD	- 21 -
3.2 DESCRIPTION OF INDICATORS AND KEYS	- 22 -
CHAPTER 4 PARAMETER FUNCTION	- 23 -
4.1 FUNCTIONAL PARAMETER	- 23 -
4.2 FAULT RECORDS	- 48 -
4.3 MONITORING PARAMETERS.....	- 49 -
CHAPTER 5 COMMUNICATION PROTOCOL	- 51 -
5.1 COMMUNICATION CONTROL ADDRESS.....	- 51 -
5.2 PARAMETER STATUS ADDRESS	- 52 -
5.3 AC DRIVE STATE AND FAULT DESCRIPTION.....	- 54 -
5.4 EEPROM-RAM ADDRESS EXCHANGE DESCRIPTION.....	- 55 -
CHAPTER 6 TROUBLESHOOTING & COUNTERMEASURES	- 56 -
6.1 FAULTS AND SOLUTIONS	- 56 -
6.2 COMMON FAULTS AND SOLUTIONS.....	- 59 -
CHAPTER 7 CONTECT SAJ	- 60 -
CHAPTER 8 WARRANTY POLICY	- 61 -
WARRANTY CARD	- 62 -

Safety precautions

■ Warning sign

⚠ DANGER: Indicates that failure to comply with the notice will result in severe personal injury or even death.

⚠ WARNING: Indicates that failure to comply with the notice will result in moderate personal injury, property damage or equipment damage.

WARNING

⊙ Do not install or operate any AC Drive that is damaged or with missing parts. Failing to follow this rule can result in facility damage or severe injury.

⊙ When installing or handling the AC Drive, please hold the bottom of the product rather than the case only, to prevent its falling and being damaged.

⊙ Install the AC Drive on nonflammable material like metal, and keep away from flammable or explosive object, heat source, and similar environment. Otherwise, fire may be caused.

⊙ When AC Drive is installed inside an electrical cabinet or other kind of enclosure, please install fans or other cooling devices, and keep ventilation well enough to ensure the enclosure temperature below 40°C, or the AC Drive may be damaged due to extreme high temperature.

⊙ Before wiring, ensure the AC Drive rated input voltage and phases are compatible with the input power source, or fire or personal injury may be caused.

⊙ Never connect the AC power supply to output terminals U, V and W. Otherwise, the AC Drive will be damaged and the warranty is invalid.

⊙ Never carry out withstand voltage test to the AC Drive, for example by a megohmmeter. Otherwise, it may cause damage to the AC Drive.

⊙ The connecting cable of the main circuit terminal should use an insulating sleeve.

⊙ When the cable length between the AC Drive and the motor exceeds 50 meters, an output reactor is recommended to be used.

- ◎Do not use a circuit breaker to control the start and stop of the AC Drive. Otherwise, the AC Drive may be damaged.
- ◎Since the AC Drive makes the motor running speed from low to high in a short time, please confirm that the motor and equipment are in the allowed running range before running.
- ◎Do not touch due to high temperature of the heat sink and braking resistor.
- ◎The factory parameters of the AC Drive can meet the requirements of most equipment operation. Under normal circumstances, please do not modify the AC Drive parameters at will. Even if there is some special applications need to change the AC Drive parameters, only necessary parameters could be changed. Otherwise, AC Drive damage may be caused.
- ◎The PCB board has a CMOS integrated circuit. Do not touch it with your hands, otherwise, static electricity will damage the PCB board.

DANGER

- ◎Wiring must be completed by qualified professional electricians, otherwise, there may be electric shock or damage to the AC Drive.
- ◎The power must be disconnected during wiring; otherwise, it may cause electric shock or fire.
- ◎The grounding terminal should be effectively grounded; otherwise, the outer casing of the AC Drive may be energized.
- ◎Do not touch the main circuit terminals, otherwise, it may cause electric shock.
- ◎Terminals for brake resistor are (+) and PB. Do not wire to other terminals, otherwise, fire may be caused.
- ◎It is only allowed to power on the AC Drive after the wiring is finished and its cover is reinstalled. It is strictly prohibited to remove the cover of AC Drive while power is on. Otherwise, it may cause electric shock.
- ◎Before programming the AC Drive with fault auto reset or restart option after power off, the mechanical device need to be implemented with safety protection measures first. Otherwise, personal injury will be caused.

◎“ STOP/RESET” key may become invalid as a result of some function setting. It is recommended to install an independent emergency circuit breaker for the AC Drive control system, otherwise, or personal injury may be caused.

◎When the power is on, there may be electricity in the AC Drive’s terminals even if it is in stop mode. Do not touch U, V, W terminals and motor connection terminals, or electrical shock may be caused.

◎Never touch the AC Drive connection terminals when power is on. Otherwise, it may cause an electrical shock.

◎Only qualified electricians can be authorized to do the jobs of maintenance, checking, or parts replacement.

◎After the power supply is OFF, make sure the charge LED is OFF and the residual voltage does not exist, or wait for at least 10 minutes before carrying out maintenance or inspection. Otherwise, damage or injury may be caused.

◎Modification to the AC Drive without permission is strictly prohibited, otherwise, severe injury may be caused. Arbitrarily modification of AC Drive will result in service warranty invalid.

Chapter 1 Product information

1.1 Technical specifications

Item		Specifications	
Control features	Control mode	Sensorless vector control (SVC)	V/F control
	Startup torque	0.5Hz/150%	0.5Hz/100%
	Speed range	1: 100	1: 50
	Speed stability accuracy	±0.5%	±1%
	Carrier frequency	0.5kHz ~ 16kHz; the carrier frequency is automatically adjusted based on the load features.	
	Overload capacity	G type: 60s for 150% of the rated current, 1s for 180% of the rated current. P type: 60s for 120% of the rated current, 1s for 150% of the rated current.	
	Torque boost	Fixed boost; Customized boost 0.1% ~ 30.0%.	
Input and Output	Input voltage range	220V/380V; fluctuation range :±15%	
	Input frequency range	50/60Hz; fluctuation range :±5%	
	Output voltage range	0-input voltage; the error is less than 5%	
	Output frequency range	SVC: 0-320Hz; V/F: 0-1000Hz	
Running control	Running command source	Three command source : keypad; control terminals; serial communication port. You can perform switchover between these sources in various ways.	
	Frequency source	There are 10 frequency sources in total, such as digital setting, analog voltage setting, analog current setting, pulse setting and serial communication port setting. You can perform switchover between these sources in various ways.	
	Auxiliary frequency source	There are ten auxiliary frequency sources. It can implement fine tuning of auxiliary frequency and frequency synthesis.	
	Input terminal	<ul style="list-style-type: none"> ◆ 6 digital input terminals (DI), ◆ 2 analog input terminals (AI). 	

Item		Specifications
	Output terminal	<ul style="list-style-type: none"> ◆ 1 open-collector output terminal ◆ 2 relay output terminal. ◆ 2 analog output terminal .
Basic function	DC braking	Braking time: 0.0s ~ 100.0s; Braking action current value: 0.0% ~ 100.0%
	V/F curve	Three modes: straight-line V/F curve, multi-point V/F curve, square V/F curve.
	Ramp mode	Straight-line ramp, S-curve ramp; Four kinds of acceleration/deceleration time with the range of 0.0-6500.0s.
	Simple PLC/Multiple speeds	It implements up to 16 speeds via the simple PLC function or combination of DI terminal states.
	Built-in PID	It realizes process-controlled closed loop control system easily.
	AVR function	It can keep constant output voltage automatically when the mains voltage changes.
	Overvoltage/Overcurrent stall control	The current and voltage are limited automatically during the running process so as to avoid frequent tripping due to overvoltage and overcurrent.
	Rapid current limit	It helps to avoid frequent overcurrent faults of the AC Drive.
	Torque limit and control	It can limit the torque automatically and prevent frequent over current tripping during the running process.
	Timing control	Timing control function: time range: 0h ~ 65535h
	Protection mode	Motor short-circuit detection at power-on, input/output phase loss protection, overcurrent protection, overvoltage protection, undervoltage protection, overheat protection, overload protection and so on.
Display and Key operation	LED display	It displays the parameters.
	Parameters locking function	It can lock the parameters to prevent malfunction.
	MF.K key	Programmable key: command source switchover/ forward and reverse running/ JOG running/menu mode switchover
Environment	Installation location	Indoor, free from direct sunlight, dust, corrosive gas, combustible gas, oil smoke, vapour, drip or salt.
	Altitude	Lower than 1000m. When it is higher than 1000m, for every 100m, it needs to reduce power by 1%, and the maximum altitude is 3000m.

Item		Specifications
	Ambient temperature	-10°C ~ 40°C. When it is higher than 40°C, for every 1°C, it needs to reduce power by 1%, and the maximum ambient temperature is 50°C
	Humidity	≤95%RH, without condensing
	Vibration	Less than 5.9m/s ² (0.6g)
	Storage temperature	-25°C ~ +60°C

Table 1-1-1 Technical specification

1.2 Product nameplate

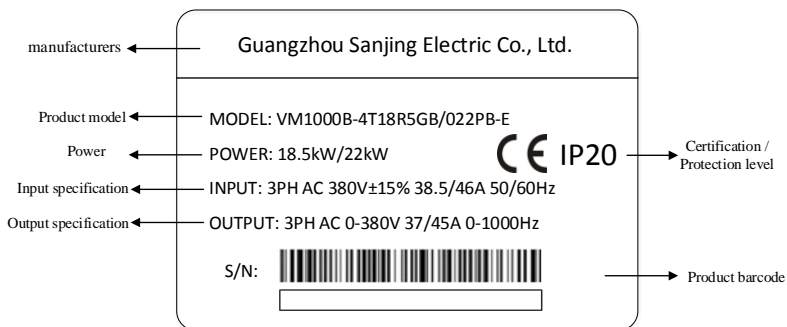


Figure 1-2-1 Product nameplate

1.3 Model description

VM1000B - 4 T 18R5GB / 022PB - E

① ② ③ ④ ⑤ ⑥

Field	No.	Identification	Description
Product series	①	Product series	VM1000B: general vector series
Voltage grade	②	Voltage grade	2: 220VAC; 4: 380VAC
The input power	③	Power phase identification	S: single ; T: three-phase
Rated power 1	④	The power range of G type	18R5: 18.5kW, R is the decimal point G—Constant torque load B—Built-in brake unit
Rated power 2	⑤	The power range of P type	022: 22kW P—Variable torque load B—Built-in brake unit
Product model suffix	⑥	Supported language	English

Table 1-3-1 VM1000B series model field comment

1.4 Product model

AC Drive Model	Rated power	Power capacity	Input current	Output current	Motor G/P	
	kW	kVA	A	A	kW	HP
Single-phase 220V						
VM1000B-2SR75GB-E	0.75	1.5	8.2	4.5	0.75	1
VM1000B-2S1R5GB-E	1.5	3	14	7	1.5	2
VM1000B-2S2R2GB-E	2.2	4	23	9.6	2.2	3
Three-phase 220V						
VM1000B-2TR75GB-E	0.75	1.5	5.0	3.8	0.75	1
VM1000B-2T1R5GB-E	1.5	3	5.8	5.1	1.5	2
VM1000B-2T2R2GB-E	2.2	4	10.5	9	2.2	3
VM1000B-2T004GB-E	4	5.9	14.6	13	4	5.5
VM1000B-2T5R5GB-E	5.5	8.9	26	25	5.5	7.5
VM1000B-2T7R5GB-E	7.5	11	35	32	7.5	10
VM1000B-2T011GB-E	11	17	46.5	45	11	15
VM1000B-2T015G-E	15	21	62	60	15	20
Three-phase 380V						
VM1000B-4TR75GB-E	0.75	1.5	3.4	2.5	0.75	1
VM1000B-4T1R5GB-E	1.5	3	5.0	3.8	1.5	2
VM1000B-4T2R2GB-E	2.2	4	5.8	5.1	2.2	3
VM1000B-4T004GB/5R5PB-E	4/5.5	5.9/8.9	10.5/14.6	9/13	4/5.5	5.5/7.5
VM1000B-4T5R5GB/7R5PB-E	5.5/7.5	8.9/11	14.6/20.5	13/17	5.5/7.5	7.5/10
VM1000B-4T7R5GB-E	7.5	11	20.5	17	7.5	10
VM1000B-4T011GB/015PB-E	11/15	17/21	26/35	25/32	11/15	15/20
VM1000B-4T015GB/18R5PB-E	15/18.5	21/24	35/38.5	32/37	15/18.5	20/25

AC Drive Model	Rated power	Power capacity	Input current	Output current	Motor G/P	
	kW	kVA	A	A	kW	HP
VM1000B-4T18R5GB/022PB-E	18.5/22	24/30	38.5/46	37/45	18.5/22	25/30
VM1000B-4T022GB/030PB-E	22/30	30/40	46.5/62	45/60	22/30	30/40
VM1000B-4T030G/037P-E	30/37	40/57	62/76	60/75	30/37	40/50
VM1000B-4T037G/045P-E	37/45	57/69	76/92	75/91	37/45	50/60
VM1000B-4T045G/055P-E	45/55	69/85	92/113	91/110	45/55	60/70
VM1000B-4T055G/075P-E	55/75	85/114	113/157	112/150	55/75	70/100
VM1000B-4T075G/093P-E	75/93	114/134	157/180	150/170	75/93	100/125
VM1000B-4T093G/110P-E	93/110	134/160	180/214	170/210	93/110	125/150
VM1000B-4T110G/132P-E	110/132	160/192	214/256	210/253	110/132	150/180
VM1000B-4T132G/160P-E	132/160	192/231	256/307	253/304	132/160	180/220
VM1000B-4T160G/185P-E	160/185	231/245	307/345	304/340	160/185	220/250
VM1000B-4T185G/200P-E	185/200	245/260	345/385	340/377	185/220	250/275
VM1000B-4T200G/220P-E	200/220	260/280	385/430	377/426	200/220	275/300
VM1000B-4T220G/250P-E	220/250	280/355	430/468	426/465	220/250	300/340
VM1000B-4T250G/280P-E	250/280	355/396	468/525	465/520	250/280	340/380
VM1000B-4T280G/315P-E	280/315	396/445	525/590	520/585	280/315	380/430
VM1000B-4T315G/355P-E	315/355	445/500	590/665	585/650	315/355	430/480
VM1000B-4T355G/400P-E	355/400	500/565	665/785	650/725	355/400	480/545
VM1000B-4T400G-E	400	565	785	725	400	545

Table 1-4-1 Product model table

Chapter 2 Installation

2.1 Overall structural drawing (unit: mm)

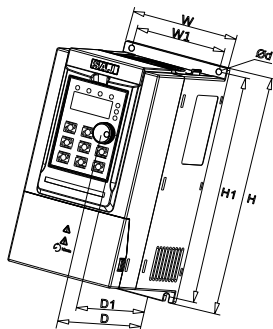


Figure 2-1-1 Outline dimension diagram 1

AC Drive Model	Overall Dimensions				Mounting Hole		Aperture
	H	W	D	D1	H1	W1	d
VM1000B-2SR75GB-E	187	88	138	130	177	73	5
VM1000B-2S1R5GB-E							
VM1000B-2S2R2GB-E							
VM1000B-2TR75GB-E							
VM1000B-2T1R5GB-E							
VM1000B-4TR75GB-E							
VM1000B-4T1R5GB-E							
VM1000B-4T2R2GB-E	207	100	147	139	197	85	5
VM1000B-2T2R2GB-E							
VM1000B-4T004GB/5R5PB-E	247	130	167	159	237	113	5
VM1000B-2T004GB-E							
VM1000B-4T5R5GB/7R5PB-E							
VM1000B-4T7R5GB-E							

Table 2-1-1 Outline dimension 1

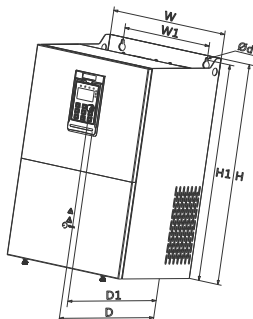


Figure 2-1-2 Outline dimension diagram 2

AC Drive Model	Overall Dimensions				Mounting Hole		Aperture
	H	W	D	D1	H1	W1	d
VM1000B-2T5R5GB-E	348	182	211	196	331	156	6
VM1000B-2T7R5GB-E							
VM1000B-4T011GB/015PB-E							
VM1000B-4T015GB/18R5PB-E							
VM1000B-2T011GB-E	373	220	205	190	356	156	6
VM1000B-4T18R5GB/022PB-E							
VM1000B-4T022GB/030PB-E							
VM1000B-2T015GB-E	435	256	222	208	419	170	6
VM1000B-4T030G/037P-E							
VM1000B-4T037G/045P-E							
VM1000B-4T045G/055P-E	543	310	280	265	523	245	10
VM1000B-4T055G/075P-E							
VM1000B-4T075G/093P-E	580	358	328	314	560	270	10
VM1000B-4T093G/110P-E							
VM1000B-4T110G/132P-E							

Table 2-1-2 Outline dimension 2

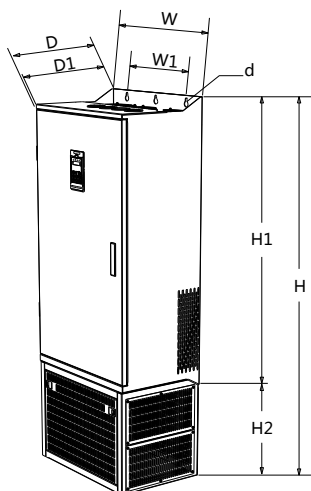


Figure 2-1-3 Outline dimension diagram 3

AC Drive Model	Overall Dimensions					Mounting Hole		Aperture
	H	H2	W	D	D1	H1	W1	d
VM1000B-4T132G/160P-E	1199	350	502	355	342	842	320	10
VM1000B-4T160G/185P-E								
VM1000B-4T185G/200P-E								
VM1000B-4T200G/220P-E	1570	426	600	408	398	1147	400	12
VM1000B-4T220G/250P-E								
VM1000B-4T250G/280P-E								
VM1000B-4T280G/315P-E								
VM1000B-4T315G/355P-E	1696	426	800	408	398	1266	520	12
VM1000B-4T355G/400P-E								
VM1000B-4T400G-E								

Table 2-1-3 Outline dimension 3

2.2 Keypad and installation

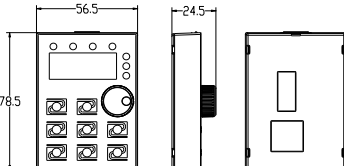
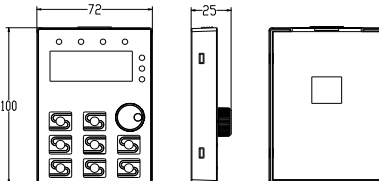
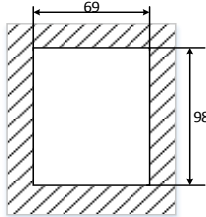
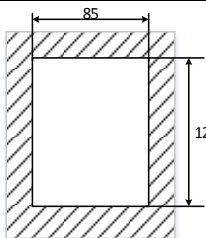
Power range	Single-phase 220V :0.75kW-2.2kW Three-phase 220V :0.75kW-4kW Three-phase 380V :0.75kW-7.5kW	Three-phase 220V :5.5kW-15kW Three-phase 380V :11kW-400kW
Keypad (Unit : mm)		
Size		
Keypad bracket (Unit : mm)		
Size		
If it is necessary to install the keypad externally, please use it together with the keypad bracket. And the keypad bracket is not built-in. If necessary, please purchase it separately.		

Table 2-2-1 Keypad related size information table

2.3 Main circuit connection

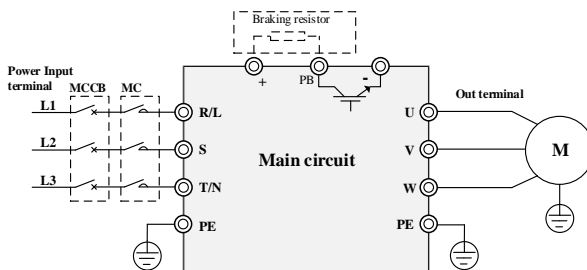


Figure 2-3-1 Main circuit wiring diagram 1

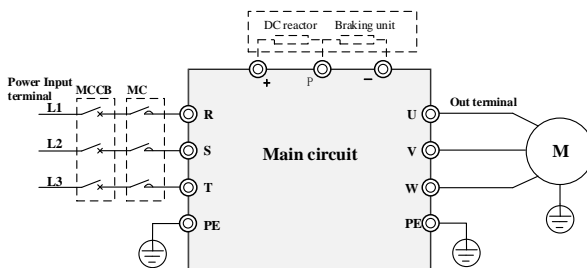


Figure 2-3-2 Main circuit wiring diagram 2

Terminal mark	Name	Description
R/L、S、T/N	Power supply input terminals	Connect to the AC power supply
(+), (-)	Positive and negative terminals of DC bus	Common DC busbar input terminal External brake unit connection terminal
(+), PB	Brake resistance connecting terminal.	Connect to the braking resistor
P、(+)	Connecting terminals of DC reactor	Dc reactor connection terminal 30kW-110kW: External dc reactor 132kW-400kW: Built - in DC reactor
U、V、W	AC drive output terminals	Connect the three-phase motor.
	Grounding terminal	Must be grounded.

Table 2-3-1 Main circuit terminals and function

2. 4 Control circuit connection

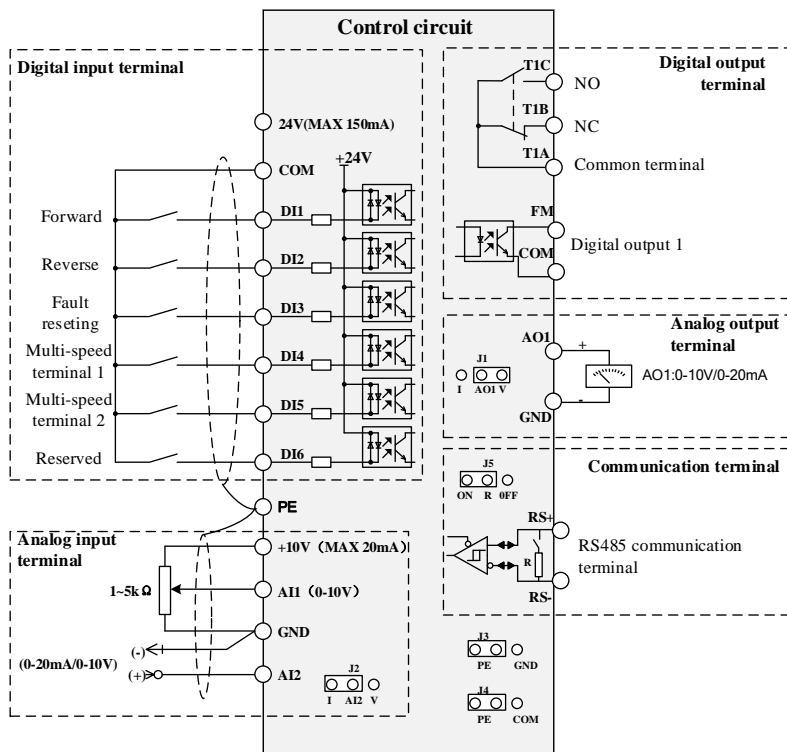


Figure 2-4-1 Control terminal diagram 1

Model reference:

Single-phase 220V :0.75kW-2.2kW

Three-phase 220V :0.75kW-4kW

Three-phase 380V :0.75kW-7.5kW

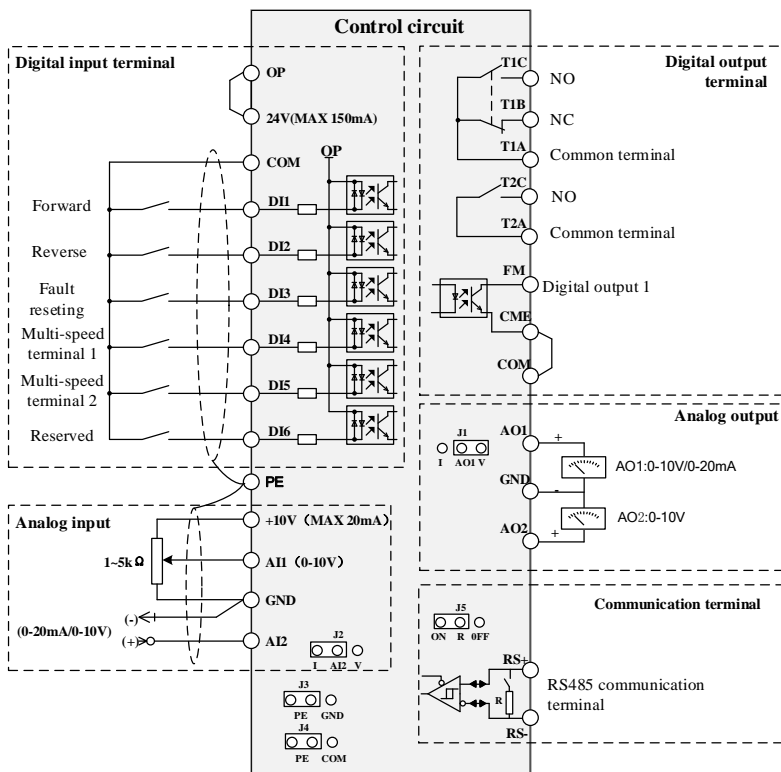


Figure 2-4-2 Control terminal diagram 2

Model reference:

Three-phase 220V : 5.5kW-15kW

Three-phase 380V : 11kW-400kW

■ Control terminal instruction

Category	Terminal symbol	Terminal name	Function description
Power supply	+10V-GND	+10V power supply	Provide +10V power supply to external unit. Generally, it provides power supply to external potentiometer with resistance range of 1-5 k Ω . Maximum output current: 20 mA
	+24V-COM	+24V power supply	Provide +24V power supply to external unit. Generally, it provides power supply to DI/DO terminals and external sensors. Maximum output current: 150 mA
	OP	External power input terminal	Connect to +24V by default. When DI1-DI6 need to be driven by external signal, OP needs to be connected to external power supply and be disconnected from +24V.
Analog input	AI1-GND	Analog input terminal 1	1. Input voltage range: 0-10V 2. Input resistance: 22 k Ω
	AI2-GND	Analog input terminal 2	1. Input range: 0-10V/4-20mA, decided by jumper J8 on the control board. 2. Input resistance: 22 k Ω (voltage input), 500 Ω (current input)
Digital input	DI1	Digital input 1	1. Optical coupling isolation, compatible with dual polarity input 2. Input resistance: 3k Ω 3. Voltage range for level input: 9V -30V
	DI2	Digital input 2	
	DI3	Digital input 3	
	DI4	Digital input 4	
	DI5	Digital input 5	
	DI6	Digital input 6	
Analog output	AO1-GND	Analog output 1	AO1: Voltage or current output is decided by jumper J5. Output voltage range: 0-10V
	AO2-GND	Analog output 2	Output current range: 0-20mA AO2: Output voltage range: 0-10V
Digital output	FM-CME	Digital output/high-speed pulse output	open collector output Output voltage range: 0V -24V Output current range: 0mA - 50mA Note that CME and COM are internally insulated, but they are shorted by jumper externally. If you want to drive FM by external power supply, Please remove the jumper.

Category	Terminal symbol	Terminal name	Function description
Relay output	T1A-T1B	NO terminal	Contact driving capacity: AC 250V, 3A, COS ϕ =0.4; DC 30V, 1A.
	T1A-T1C	NC terminal	
	T2A-T2C	NO terminal	
Communication port and socket		RS+	RS485 signal positive terminal
		RS-	RS485 signal negative terminal

Table 2-4-1 Control terminal instruction

Chapter 3 Display and operation

3.1 Keypad

You can modify the parameters, monitor the working status and start or stop the AC Drive by operating the keypad, as shown in the following figure.

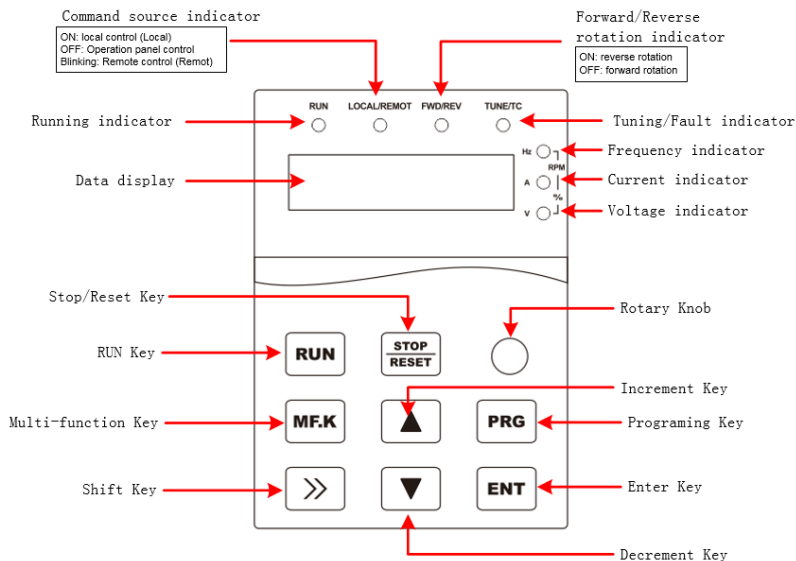


Figure 3-1-1 Keypad diagram

3.2 Description of indicators and keys

Item	Name	Function
Indicator	Unit indicators	<ul style="list-style-type: none"> ◆ Hz: Unit of frequency; ◆ A:Unit of current; ◆ V:Unit of voltage; ◆ RPM (Hz+A) : Unit of rotational speed; ◆ % (A+V) : Percentage
	Status	<ul style="list-style-type: none"> ◆ RUN: ON/Running; OFF/Stop ◆ FWD/REV: ON/Forward rotation; OFF/Reverse rotation; Blinking/Forward and reverse switching ◆ TUNE/TC: Blinking slowly/Auto-tuning state; Blinking quickly/Fault state; ◆ LOCAL/REMOTE: ON/Terminal control; Blinking/Communication; OFF/keypad control
Key	PRG (Programming)	Enter or exit the first menu.
	ENT (Confirm)	Enter the menu interfaces and confirm the parameter setting.
	△ (Increment)	Increase data or function code.
	▽ (Decrement)	Decrease data or function code.
	>> (Shift)	Select the displayed parameters in the stop or running state and select the digit to be modified when modifying parameters.
	RUN	Start the AC Drive in keypad control mode.
	STOP/RESET	Stop the AC Drive when it is in the running state and perform the reset operation when it is in the fault state. The functions of this key are restricted in F7.02.
MF.K (Multi-functional choice)	Perform function switchover according to the setting of F7.01.	
Knob	Pulse potentiometer	Can be used as frequency source. When used as a frequency source, clockwise rotation increases the frequency and counterclockwise rotation decreases the frequency.

Table 3-2-1 Description of Indicators and key

Chapter 4 Parameter function

“○”: the parameter can be modified in both standby and operating state;

“●”: the parameter can't be modified in operating state;

“◎”:the parameter is the actual detected and recorded value which can't be modified;

Note: the communication address is hexadecimal.

4.1 Functional parameter

Function Code	Parameter Name	Setting Range	Default	Property	Add. HEX
F0 Group: basic function					
F0.00	Motor control mode	0:Sensorless vector control (SVC) 1: V/F control	1	●	0000
F0.01	Command source selection	0: Keypad control (LED off) 1: Terminal control (LED on) 2: Communication LED (LED blinking)	0	●	0001
F0.02	UP/DOWN standard	0: Operating frequency 1: Setting frequency	1	●	0002
F0.03	Setting main frequency source X	0: Digital setting (non-retentive at power failure) 1: Digital setting (retentive at power failure) 2: AI1 3: AI2 4: Reserved 5: Reserved 6: Multi-speed instructions 7: Simple PLC 8: PID 9: Communication setting	1	○	0003
F0.04	Setting auxiliary frequency source Y	Same as F0.03(Settings of main frequency source X)	0	○	0004
F0.05	Range of auxiliary frequency source Y	0: Relative to the maximum frequency 1: Relative to frequency source X	0	○	0005
F0.06	Percentage range of auxiliary frequency source Y	0% ~ 150%	100%	○	0006
F0.07	Frequency reference selection	Single-digit: Selection of frequency source selection	0	○	0007

Function Code	Parameter Name	Setting Range	Default	Property	Add. HEX
		0: main frequency source X 1: main and auxiliary operation results 2: Switchover between X and Y 3: Switchover between X and main (X) & auxiliary (Y) operation 4: Switchover between Y and main (X) & auxiliary (Y) operation Ten's digit: X and Y operation relationship 0: X+Y 1: X-Y 2: Maximum 3: Minimum 4: X*Y			
F0.08	Keypad setting frequency	0.00Hz ~ F0.10	50.00Hz	○	0008
F0.09	Running direction selection	0: Same direction 1: Reverses direction	0	○	0009
F0.10	Maximum frequency	50.00Hz ~ 320.00Hz	50.00Hz	●	000A
F0.11	Source of frequency upper limit	0: Set by F0.12 1: AI1 2: AI2 3: Reserved 4: Reserved 5: Communication setting	0	●	000B
F0.12	Frequency upper limit	Frequency lower limit (F0.14)~F0.10	50.00Hz	○	000C
F0.13	Upper limit frequency offset	0.00Hz ~ F0.10	0.00Hz	○	000D
F0.14	Frequency lower limit	0.00Hz ~ F0.12	0.00Hz	○	000E
F0.15	The function of frequency lower limit	0: Running at frequency lower limit 1: Stop 2: Standby	0	○	000F
F0.16	Carrier frequency	0.5kHz ~ 16.0kHz	Model dependent	○	0010
F0.17	Reserved	-	-	-	0011
F0.18	Acceleration time 1	0.0s ~ 6500.0s	Model dependent	○	0012
F0.19	Deceleration time 1	0.0s ~ 6500.0s	Model dependent	○	0013
F0.20	Default setting restoring	0: No operation 1: Restore to factory default setting (not including F2 parameters) 2: clear fault record	0	●	0014

Function Code	Parameter Name	Setting Range	Default	Property	Add. HEX
F0.21	Function code modification attribute	0: modifiable 1: non-modifiable	0	○	0015
F0.22	Retentive of digital setting frequency	0: No retentive 1: retentive	1	●	0016
F0.23	Acceleration & deceleration time unit	0: 1 s 1: 0.1 s 2: 0.01 s	1	●	0017
F0.24	Acceleration & deceleration time of base frequency	0: Maximum frequency (F0.10) 1: Setting frequency 2: 100Hz	0	●	0018
F0.25	Fan operating mode	0: Automatic running 1: Keep running when power on	0	○	0019
F0.26	Frequency instruction decimal point	1: 1 decimal point 2: 2 decimal point	2	●	001A
F1 Group: start and stop					
F1.00	Starting mode	0: Start directly 1: Speed tracing and start 2: Pre-excitation start	0	○	0100
F1.01	Speed tracking mode	0: Start with the frequency of input power failure 1: Start at zero speed 2: Start at the maximum frequency 3: Excitation search	0	●	0101
F1.02	Speed tracking coefficient	1 ~ 100	20	○	0102
F1.03	Starting frequency	0.00Hz ~ 10.00Hz	0.00Hz	○	0103
F1.04	Hold time of starting frequency	0.0s ~ 100.0s	0.0s	●	0104
F1.05	DC braking current at start-up/Pre-excitation current	0% ~ 100%	0%	●	0105
F1.06	DC braking current at start-up/Pre-excitation time	0.0s ~ 100.0s	0.0s	●	0106
F1.07	Acceleration & deceleration method	0: Linear acceleration/deceleration 1: S-curve acceleration/deceleration A 2: S-curve acceleration/deceleration B	0	●	0107
F1.08	Time proportion of S-curve start segment	0.0% ~ (100.0%-F1.09)	30.00%	●	0108
F1.09	Time proportion of S-	0.0% ~ (100.0%-F1.08)	30.00%	●	0109

Function Code	Parameter Name	Setting Range	Default	Property	Add. HEX
	curve end segment				
F1.10	Stop mode	0: Decelerate to stop 1: Free stopping	0	○	010A
F1.11	Trigging frequency of DC braking at stop	0.00Hz ~ F0.10	0.00Hz	○	010B
F1.12	Waiting time of DC braking at stop	0.0s ~ 100.0s	0.0s	○	010C
F1.13	The current of DC braking at stop	0% ~ 100%	0%	○	010D
F1.14	The time of DC braking at stop	0.0s ~ 100.0s	0.0s	○	010E
F1.15	Brake use rate	0% ~ 100%	100%	○	010F
F1.16	Zero frequency output selection	0: Open 1: Closed	1	●	0110
F2 Group: motor parameters					
F2.00	Motor type selection	0: Ordinary asynchronous motor 1: Variable frequency asynchronous motor	0	●	0200
F2.01	Motor rated power	0.1kW ~ 400.0kW	Model dependent	●	0201
F2.02	Motor rated voltage	1V ~ 440V	Model dependent	●	0202
F2.03	Motor rated current	0.01A ~ 655.35A (<=55kW) 0.1A ~ 6553.5A (>55kW)	Model dependent	●	0203
F2.04	Motor rated frequency	0.01Hz ~ F0.10	Model dependent	●	0204
F2.05	Motor rated rotation speed	1rpm ~ 36000rpm	Model dependent	●	0205
F2.06	Asynchronous motor stator resistance	0.001Ω ~ 65.535Ω (<=55kW) 0.0001Ω ~ 6.5535Ω (>55kW)	Model dependent	●	0206
F2.07	Asynchronous motor rotator resistance	0.001Ω ~ 65.535Ω (<=55kW) 0.0001Ω ~ 6.5535Ω (>55kW)	Model dependent	●	0207
F2.08	Asynchronous motor leakage inductance	0.01Mh ~ 655.35Mh (<=55kW) 0.001Mh ~ 65.535Mh (>55kW)	Model dependent	●	0208
F2.09	Asynchronous motor mutual inductance	0.1Mh ~ 6553.5Mh (<=55kW) 0.01Mh ~ 655.35Mh (>55kW)	Model dependent	●	0209
F2.10	Asynchronous motor no-load current	0.01A ~ F2.03 (<=55kW) 0.1A ~ F2.03 (>55kW)	Model dependent	●	020A
F2.11	Tuning selection	0: No operation	0	●	020B

Function Code	Parameter Name	Setting Range	Default	Property	Add. HEX
		1: The asynchronous machine static tuning. 2: The asynchronous machine is fully tuned			
F2.12	G/P type selection	1: General model (G) (constant torque load model) 2: Pump model (P) (draught fan, water pump type load model)	Model dependent	●	020C
F3 Group: vector parameters					
F3.00	Speed loop proportional gain 1	1 ~ 100	30	○	0300
F3.01	Speed loop integral time 1	0.01s ~ 10.00s	0.50s	○	0301
F3.02	Switchover frequency 1	0.00 ~ F3.05	5.00Hz	○	0302
F3.03	Speed loop proportional gain 2	1 ~ 100	20	○	0303
F3.04	Speed loop integral time 2	0.01s ~ 10.00s	1.00s	○	0304
F3.05	Switchover frequency 2	F3.02 ~ F0.10	10.00Hz	○	0305
F3.06	Slip compensation coefficient of vector control	50% ~ 200%	100%	○	0306
F3.07	Speed loop filter time constant.	0.000s ~ 0.100s	0.000s	○	0307
F3.08	Speed control torque upper limit	0.0% ~ 200.0%	150.00%	○	0308
F3.09	Speed/torque control	0: Speed control 1: Torque control	0	●	0309
F3.10	Torque upper limit source in torque control	0: Digital setting 1: AI1 2: AI2 3: Reserved 4: Reserved 5: Communication setting 6: MIN(AI1,AI2) 7: MAX(AI1,AI2)	0	●	030A
F3.11	Digital setting of torque upper limit in torque control	-200.0% ~ 200.0%	150.00%	○	030B
F3.12	Forward maximum frequency of torque control	0.00Hz ~ F0.10	50.00Hz	○	030C
F3.13	Reverse maximum frequency of torque	0.00Hz ~ F0.10	50.00Hz	○	030D

Function Code	Parameter Name	Setting Range	Default	Property	Add. HEX
	control				
F3.14	Acceleration time of torque control	0.00s ~ 650.00s	0.00s	○	030E
F3.15	Deceleration time of torque control	0.00s ~ 650.00s	0.00s	○	030F
F3.16	Torque stiffness coefficient	10.0%~120.0%	100.00%	●	0310
F3.17	M axis current loop proportional gain	0 ~ 60000	2000	○	0311
F3.18	M axis current loop integral gain.	0 ~ 60000	1300	○	0312
F3.19	T axis current proportional gain	0 ~ 60000	2000	○	0313
F3.20	T axis current integral gain	0 ~ 60000	1300	○	0314
F3.21	The speed loop integral separation	0: Invalid 1: Valid	0	○	0315
F3.22	Reserved	-	-	-	0316
F3.23	Reserved	-	-	-	0317
F3.24	Torque mode friction compensation coefficient	0 ~ 300	100	●	0318
F3.25	Torque mode friction compensation time	0 ~ 100.0s	0	●	0319
F4 Group: control parameters					
F4.00	V/F curve setting	0: Linear V/F 1: Multi-point V/F 2: Square V/F 3~9: Reserved 10: V/F complete separation 11: V/F half separation	0	●	0400
F4.01	Torque boost	0.0% (fixed torque boost) 0.1% ~ 30.0%	Model dependent	○	0401
F4.02	Cut-off frequency of torque boost	0.00Hz ~ F0.10	50.00Hz	●	0402
F4.03	Multipoint V/F frequency 1	0.00Hz ~ F4.05	0.00Hz	●	0403
F4.04	Multipoint V/F voltage 1	0.0% ~ 100.0%	0.00%	●	0404
F4.05	Multipoint V/F frequency 2	F4.03 ~ F4.07	0.00Hz	●	0405

Function Code	Parameter Name	Setting Range	Default	Property	Add. HEX
F4.06	Multipoint V/F voltage 2	0.0% ~ 100.0%	0.00%	●	0406
F4.07	Multipoint V/F frequency 3	F4.05 ~ F2.04	0.00Hz	●	0407
F4.08	Multipoint V/F voltage 3	0.0% ~ 100.0%	0.00%	●	0408
F4.09	V/F slip compensation	0.0% ~ 200.0%	80.00%	○	0409
F4.10	V/F over-excitation gain	0 ~ 200	0	○	040A
F4.11	V/F oscillation suppression gain	0 ~ 100	Model dependent	○	040B
F4.12	Voltage source for V/F separation	0: Digital (F4.13) 1: AI1 2: AI2 3: Reserved 4: Reserved 5: Multi-speed instructions 6: Simple PLC 7: PID 8: Communication setting (100% corresponds to the rated motor voltage)	0	○	040C
F4.13	Voltage digital setting for V/F separation	0V ~ F2.02	0V	○	040D
F4.14	Voltage rise time of separation	0.0s ~ 1000.0s (It indicates the time for the voltage rising from 0 to rated motor voltage.)	0.0s	○	040E
F4.15	Reserved	-	-	-	040F
F4.16	Auto voltage regulation (AVR)	0: Disable 1: Deceleration only enable 2: Constant speed only enable 3: Enable	1	●	0410
F5 Group: input terminal					
F5.00	DI1 terminal function selection	0: No function 1: Forward running (FWD)	1	●	0500
F5.01	DI2 terminal function selection	2: Reverse running (REV) 3: Three-wire operation control	4	●	0501
F5.02	DI3 terminal function selection	4: Forward point movement (FJOG) 5: Reverse point movement (RJOG) 6: Terminal UP	9	●	0502
F5.03	DI4 terminal function selection	7: Terminal DOWN 8: Free stopping 9: Reset	12	●	0503
F5.04	DI5 terminal function selection	10: Run pause 11: External faults often open input	13	●	0504
F5.05	DI6 terminal function selection	12: Multi-speed instruction terminal 1 13: Multi-speed instruction terminal 2	0	●	0505

Function Code	Parameter Name	Setting Range	Default	Property	Add. HEX
F5.06 – F5.09	Reserved	14: Multi-speed instruction terminal 3 15: Multi-speed instruction terminal 4 16: Terminal 1 for acceleration/deceleration time selection	-	-	-
F5.10	VDI terminal function selection	17: Terminal 2 for acceleration/deceleration time selection 18: Frequency source switchover (terminal and keypad) 19: UP/DOWN setting clear 20: Command source switchover terminal 1 21: Acceleration/deceleration prohibited 22: PID pause 23: PLC status reset 24: Swing pause 25: Counter input 26: Counter reset 27: Length count input 28: Length reset 29: Torque control prohibited 30: Pulse input (only valid for DI6) 31: Reserved 32: Immediate dc braking 33: External faults often closed input 34: frequency setting effect terminal (this terminal function is not set, the default is valid) 35: Reverse PID action direction 36: External stop terminal 1 37: Command source switchover terminal 1 38: PID integral pause 39: Frequency source X and preset frequency switchover terminals 40: Frequency source Y and preset frequency switchover terminals 41 ~ 42: Reserved 43: PID parameter switchover terminal 44: User-defined fault 1 45: User-defined fault 2 46: Speed control/torque control switchover 47: Emergency stop 48: External stopping terminal 22 49: Deceleration dc braking 50: Clear the current running time 51: Timing enable 52: Timed reset 53~59: Reserved	0	●	050A
F5.11~ F5.14	Reserved		-	-	-
F5.15	DI filter time	0.000s ~ 1.000s	0.010s	○	050F
F5.16	Terminal command mode	0: Two-line mode 1 1: Two-line mode 2	0	●	0510

Function Code	Parameter Name	Setting Range	Default	Property	Add. HEX
		2: Three-line mode 1 3: Three-line mode 2			
F5.17	UP/DOWN change rate range	0.01Hz ~ 6553.5Hz	0.50Hz	○	0511
F5.18	AI1 minimum input	-10.00V ~ F5.20	0.00V	○	0512
F5.19	Percentage rate of AI1 minimum input	-100.0% ~ +100.0%	0.00%	○	0513
F5.20	AI1 maximum input	F5.18 ~ +10.00V	10.00V	○	0514
F5.21	Percentage rate of AI1 maximum input	-100.0% ~ +100.0%	100.00%	○	0515
F5.22	AI1 filter time	0.00s ~ 10.00s	0.10s	○	0516
F5.23	AI2 minimum input	-10.00V ~ F5.25	0.00V	○	0517
F5.24	Percentage rate of AI2 minimum input	-100.0% ~ +100.0%	0.00%	○	0518
F5.25	AI2 maximum input	F5.23 ~ +10.00V	10.00V	○	0519
F5.26	Percentage rate of AI2 maximum input	-100.0% ~ +100.0%	100.00%	○	051A
F5.27	AI2 filter time	0.00s ~ 10.00s	0.10s	○	051B
F5.28	Reserved	-	-	○	051C
F5.29	Reserved	-	-	○	051D
F5.30	Reserved	-	-	○	051E
F5.31	Reserved	-	-	○	051F
F5.32	Reserved	-	-	○	0520
F5.33	DI1 enable delay time	0.0s ~ 3600.0s	0.0s	○	0521
F5.34	DI2 enable delay time	0.0s ~ 3600.0s	0.0s	○	0522
F5.35	DI1 disabled delay time	0.0s ~ 3600.0s	0.0s	○	0523
F5.36	DI2 disabled delay time	0.0s ~ 3600.0s	0.0s	○	0524
F5.37	DI valid mode selection 1	0: High level 1: Low level Single digit: DI1 Ten's digit: DI2 Hundred's digit: DI3 Thousand's digit: DI4 Ten Thousand's digit: DI5	0	●	0525

Function Code	Parameter Name	Setting Range	Default	Property	Add. HEX
F5.38	DI valid mode selection 2	0: High level 1: Low level Single digit: DI6 Ten's digit: Reserved Hundred's digit: Reserved Thousand's digit: Reserved Ten Thousand's digit: Reserved	0	●	0526
F5.39	AI1 zero drift coefficient	0~50.00	0	○	0527
F5.40	AI2 zero drift coefficient	0~50.00	0	○	0528
F6 Group: output terminal					
F6.00	FM terminal out mode	0: Reserved 1: Open-collector output (FMR)	1	○	0600
F6.01	FMR function	0: No output 1: AC Drive operation	0	○	0601
F6.02	Relay 1 function	2: Fault out(stop) 3: Frequency level detection FDT1 output	2	○	0602
F6.03	Relay 2 function	4: Frequency reached	1	○	0603
F6.04~F6.05	Reserved	5: Zero-speed running(no output at stop) 6: Motor overload pre-warning 7: AC Drive overload pre-warning	-	-	-
F6.06	VDO output selection	8: Set count value reached	0	●	0606
F6.07~F6.10	Reserved	9: Designated count value reached 10: Length reached 11: PLC cycle complete 12: Accumulative running time reached 13: Frequency limited 14: Torque limited 15: Ready for running 16: AI1 larger than AI2 17: Frequency upper limit reached 18: Frequency lower limit reached 19: Undervoltage state output 20: Communication setting 21: Positioning completed (Reserved) 22: Positioning close (Reserved) 23: Zero-speed running 2 (having output at stop) 24: Accumulative power-on time reached 25: Frequency level detection FDT2 26: Frequency 1 reached 27: Frequency 2 reached 28: Current 1 reached 29: Current 2 reached 30: Timing reached 31: AI1 input limit exceeded 32: Offload 33: Running direction 34: Zero current detection	-	-	-

Function Code	Parameter Name	Setting Range	Default	Property	Add. HEX
		35: Module temperature reached 36: Software overcurrent output 37: Lower limit frequency reached (non-operational) 38: Fault output (continue operation) 39: Reserved 40: This running time arrive 41: User-defined output 1 42: User-defined output 2 43: Timer output			
F6.11	Reserved	0: Running frequency	0	○	060B
F6.12	AO1 function	1: Set frequency 2: Output current	0	○	060C
F6.13	AO2 function	3: Output torque 4: Output power 5: Output voltage 6: Reserved 7: AI1 8: AI2 9: Reserved 10: Length 11: Count vaule 12: Communication setting 13: Motor rotational speed 14: Output current (0-1000A corresponding to 0-10V) 15: Output voltage (0-1000V corresponding to 0-10V) 16: DC bus voltage (0-1000V corresponding to 0-10V)	1	○	060D
F6.14	Reserved	-	-	○	060E
F6.15	AO1 offset coefficient	-100.0% ~ 100.0%	0.00%	○	060F
F6.16	AO1 gain	-10.00 ~ 10.00	1	○	0610
F6.17	AO2 offset coefficient	-100.0% ~ 100.0%	0.00%	○	0611
F6.18	AO2 gain	-10.00 ~ 10.00	1	○	0612
F6.19	FMR connecting delay time	0.0s ~ 3600.0s	0.0s	○	0613
F6.20	Relay 1 connecting delay time	0.0s ~ 3600.0s	0.0s	○	0614
F6.21	Relay 2 connecting delay time	0.0s ~ 3600.0s	0.0s	○	0615
F6.22	VDO connecting delay time	0.0s ~ 3600.0s	0.0s	○	0616
F6.23	FMR disconnecting delay	0.0s ~ 3600.0s	0.0s	○	0617

Function Code	Parameter Name	Setting Range	Default	Property	Add. HEX
F6.24	Relay 1 disconnecting delay time.	0.0s ~ 3600.0s	0.0s	○	0618
F6.25	Relay 2 disconnecting delay time	0.0s ~ 3600.0s	0.0s	○	0619
F6.26	VDO disconnecting delay time	0.0s ~ 3600.0s	0.0s	○	061A
F6.27	Output terminal valid state selection	0: Positive logic 1: Negative logic Single digit: FDOR Ten's digit: RELAY1 Hundred's digit: RELAY2 Thousand's digit: Reserved Ten thousand's digit: Reserved	0	○	061B
F6.28	User defined output variability selection (EX)1	0: Running frequency 1: Setting frequency 2: DC bus voltage 3: Output voltage 4: Output current 5: Output power 6: Output torque 7 ~ 8: Reserved 9: AI1 input 10: AI2 input 11: Reserved 12: Count value 13: Length value	0	○	061C
F6.29	User defined comparison method 1	Single digit: comparison test method 0: Equal (EX==X1) 1: Equal or greater than 2: Equal or less than 3 Interval comparison (X1≤EX≤X2) 4: Units digit test (EX&X1=X2) Ten's digit: output method 0: False value output 1: Real value output	0	○	061D
F6.30	User defined output dead zone 1	0 ~ 65535	0	○	061E
F6.31	User-defined 1 output comparison value 1	0 ~ 65535	0	○	061F
F6.32	User-defined 1 output comparison value 2	0 ~ 65535	0	○	0620
F6.33	User defined output variability selection(EX)2	0: Running frequency 1: Setting frequency 2: DC bus voltage 3: Out voltage	0	○	0621

Function Code	Parameter Name	Setting Range	Default	Property	Add. HEX
		4: Out current 5: Out power 6: Out torque 7 ~ 8: Reserved 9: AI1 Input 10: AI2 Input 11: Reserved 12: Count value 13: Length value			
F6.34	User defined comparison method 1	Single digit: comparison test method 0: Equal (EX==X1) 1: Equal or greater than 2: Equal or less than 3 Interval comparison (X1≤EX≤X2) 4:Units digit test (EX&X1=X2) Ten's digit: output method 0: False value output 1: Real value output	0	○	0622
F6.35	User defined output dead zone 2	0 ~ 65535	0	○	0623
F6.36	User-defined 2 output comparison value 1	0 ~ 65535	0	○	0624
F6.37	User-defined 2 output comparison value 2	0 ~ 65535	0	○	0625
F6.38	The setting time of timer	0.00s~100.00s	10	○	0626
F7 Group: keypad and display					
F7.00	LCD keypad parameter copy	0: No operation 1: The native function parameters are uploaded to the LCD keypad 2: LCD keypad function parameters are downloaded to the machine	0	○	0700
F7.01	MF.K key function selection	0: MF.K disabled 1: Switchover between keypad control and remote command control (terminal or communication) 2: Switchover between forward rotation and reverse rotation 3: Forward JOG 4: Reverse JOG 5: Menu mode switching	0	●	0701
F7.02	STOP/RESET key function	0: STOP/RESET key enable only in keypad control 1: STOP/RESET key enable in any operation mode	1	○	0702

Function Code	Parameter Name	Setting Range	Default	Property	Add. HEX
F7.03	LED display running parameters 1	0000 ~ FFFF Bit00: Running frequency (Hz) Bit01: Setting frequency (Hz) Bit02: DC bus voltage (V) Bit03: Output voltage (V) Bit04: Output current (A) Bit05: Output power (kW) Bit06: Output torque (%) Bit07: DI input status Bit08: DO output status Bit09: AI1 power (V) Bit10: AI2 power (V) Bit11: Reserved Bit12: Count value Bit13: Length value Bit14: Load speed display Bit15: PID setting	17	○	0703
F7.04	LED display running parameters 2	0000 ~ FFFF Bit00: PID feedback Bit01: PLC stage Bit02: Feedback speed (0.1Hz) Bit03: Reserved Bit04: Remaining running time Bit05: AI1 voltage before correction Bit06: AI2 voltage before correction Bit07: Reserved Bit08: Linear speed Bit09: Current power-on time Bit10: Current running time Bit11: Reserved Bit12: Communication setting Bit13: Reserved Bit14: Main frequency X display Bit15: Auxiliary frequency Y display	0	○	0704
F7.05	LED display stop parameters	0000 ~ FFFF Bit00: Setting frequency (Hz) Bit01: DC bus voltage(V) Bit02: DI input status Bit03: DO output status Bit04: AI1 voltage (V) Bit05: AI2 voltage (V) Bit06: Reserved Bit07: Count value Bit08: Length value Bit09: PLC stage Bit10: Load speed display Bit11: PID setting Bit12: Reserved Bit13: PID feedback value	33	○	0705

Function Code	Parameter Name	Setting Range	Default	Property	Add. HEX
F7.06	Load speed display coefficient	0.0001 ~ 6.5000	0.3	○	0706
F7.07	Heatsink temperature of IGBT	0℃ ~ 100℃	.	●	0707
F7.08	Heatsink temperature of rectifier bridge	0℃ ~ 100℃	.	●	0708
F7.09	Accumulative running time	0h ~ 65535h	.	●	0709
F7.10	Product number	-	.	●	070A
F7.11	Software version	-	.	●	070B
F7.12	Number of decimal places for load speed display	0: 0 decimal places 1: 1 decimal places 2: 2 decimal places 3: 3 decimal places	0	○	070C
F7.13	Accumulative power-on time	0h ~ 65535h	.	●	070D
F7.14	Accumulative power consumption	0 kWh ~ 65535 kWh	.	●	070E
F7.15	Performance software version	-	.	●	070F
F8 Group: auxiliary functions					
F8.00	JOG running frequency	0.00Hz ~ F0.10	2.00Hz	○	0800
F8.01	JOG acceleration time	0.0s ~ 6500.0s	20.0s	○	0801
F8.02	JOG deceleration time	0.0s ~ 6500.0s	20.0s	○	0802
F8.03	Acceleration time 2	0.0s ~ 6500.0s	Model dependent	○	0803
F8.04	Deceleration time 2	0.0s ~ 6500.0s	Model dependent	○	0804
F8.05	Acceleration time 3	0.0s ~ 6500.0s	Model dependent	○	0805
F8.06	Deceleration time 3	0.0s ~ 6500.0s	Model dependent	○	0806
F8.07	Acceleration time 4	0.0s ~ 6500.0s	Model dependent	○	0807
F8.08	Deceleration time 4	0.0s ~ 6500.0s	Model dependent	○	0808
F8.09	Jump frequency 1	0.00Hz ~ F0.10	0.00Hz	○	0809
F8.10	Jump frequency 2	0.00Hz ~ F0.10	0.00Hz	○	080A

Function Code	Parameter Name	Setting Range	Default	Property	Add. HEX
F8.11	Frequency jump amplitude	0.00Hz ~F0.10	0.01Hz	○	080B
F8.12	Forward/Reverse rotation dead-zone time	0.0s ~ 3000.0s	0.0s	○	080C
F8.13	Reverse control	0: Enabled 1: Disabled	0	○	080D
F8.14	The carrier frequency is adjusted with temperature	0: No 1: Yes	1	○	080E
F8.15	Droop control	0.00Hz ~ 10.00Hz	0.00Hz	○	080F
F8.16	Setting of accumulated power-on arrive time	0h ~ 65000h	0h	○	0810
F8.17	Setting of accumulated running arrive time	0h ~ 65000h	65000h	○	0811
F8.18	Startup protection	0: No 1: Protection	0	○	0812
F8.19	Frequency detection value (FDT1)	0.00Hz ~F0.10	50.00Hz	○	0813
F8.20	Frequency detection hysteresis (FDT1)	0.0% ~ 100.0% (FDT1 level)	5.0%	○	0814
F8.21	Detection range of frequency reached	0.0% ~ 100.0% (maximum frequency)	0.00%	○	0815
F8.22	Jump frequency during acceleration/deceleration	0: Disabled 1: Enabled	0	○	0816
F8.23	Accumulated running time arrive selection	0:Keep running 1:Fault warning	0	●	0817
F8.24	Accumulated power-on time arrive action selection	0:Keep running 1:Fault warning	0	●	0818
F8.25	Acceleration time 1/2 switching frequency point	0.00Hz ~F0.10	0.00Hz	○	0819
F8.26	Deceleration time 1/2 switch frequency point.	0.00Hz ~F0.10	0.00Hz	○	081A
F8.27	Terminal JOG preferred	0: Disabled 1: Enabled	1	○	081B
F8.28	Frequency detection value (FDT2)	0.00Hz ~F0.10	50.00Hz	○	081C
F8.29	Frequency detection hysteresis (FDT2)	0.0% ~ 100.0% (FDT2 level)	5.00%	○	081D
F8.30	Any frequency reaching detection value 1	0.00Hz ~F0.10	50.00Hz	○	081E

Function Code	Parameter Name	Setting Range	Default	Property	Add. HEX
F8.31	Any frequency reaching detection amplitude 1	0.0% ~ 100.0% (maximum frequency)	0.00%	○	081F
F8.32	Any frequency reaching detection value 2	0.00Hz ~ F0.10	50.00Hz	○	0820
F8.33	Any frequency reaching detection amplitude 2	0.0% ~ 100.0% (maximum frequency)	0.00%	○	0821
F8.34	Zero current detection level	0.0% ~ 300.0% (motor rated current)	5.00%	○	0822
F8.35	Zero current detection delay time	0.01s ~ 600.00s	0.10s	○	0823
F8.36	Software overcurrent point	0.0% (no detection) 0.1% ~ 300.0%(motor rated current)	200.00%	○	0824
F8.37	Software overcurrent detection delay time	0.00s ~ 600.00s	0.00s	○	0825
F8.38	Any current reaching 1	0.0% ~ 300.0%(motor rated current)	100.00%	○	0826
F8.39	Any current reaching 1 amplitude	0.0% ~ 300.0%(motor rated current)	0.00%	○	0827
F8.40	Any current reaching 2	0.0% ~ 300.0%(motor rated current)	100.00%	○	0828
F8.41	Any current reaching 2amplitude	0.0% ~ 300.0%(motor rated current)	0.00%	○	0829
F8.42	Timing function	0: Disabled 1: Enabled	0	●	082A
F8.43	Timing duration source	0: F8.44 1: AI1 2: AI2 3: Reserved	0	●	082B
F8.44	Timing duration	0.0Min ~ 6500.0Min	0.0Min	●	082C
F8.45	AI1 input voltage lower limit	0.00V ~ F8.46	3.10V	○	082D
F8.46	AI1 input voltage upper limit	F8.45 ~ 10.00V	6.80V	○	082E
F8.47	IGBT temperature threshold	0℃~ 100℃	75℃	○	082F
F8.48	Fast current limiting	Single-digit: 0: Disabled 1: Enabled Ten's digit: 0: Disable Err40 Display 1: Enabled Err40 Display	11	○	0830
F8.49	Random carrier mode	0: Closed 1: Random carrier mode 1	1	○	0831

Function Code	Parameter Name	Setting Range	Default	Property	Add. HEX
		2: Random carrier mode 2 3: Random carrier mode 3 4: Random carrier mode 4 5: Random carrier mode 5 6~10: Reserved			
F9 Group: process control PID function					
F9.00	PID setting source	0: F9.01 1: AI1 2: AI2 3: Reserved 4: Reserved 5: Communication setting 6: Multi-speed instructions	0	○	0900
F9.01	PID digital setting	0.0% ~ 100.0%	50.0%	○	0901
F9.02	PID feedback source	0: AI1 1: AI2 2: Reserved 3: AI1-AI2 4: Reserved 5: Communication setting 6: AI1+AI2 7: MAX(AI1 , AI2) 8: MIN(AI1 , AI2)	0	○	0902
F9.03	PID controlling direction	0: Positive 1: Negative	0	○	0903
F9.04	PID setting feedback range	0 ~ 65535	1000	○	0904
F9.05	Proportional gain P1	0.0 ~ 1000.0	20	○	0905
F9.06	Integral time I1	0.00s ~ 10.00s	2.00s	○	0906
F9.07	Differential time D1	0.000s ~ 10.000s	0.000s	○	0907
F9.08	PID reverse cut-off frequency	0.00 ~ F0.10	0.00Hz	○	0908
F9.09	PID deviation limit	0.0% ~ 100.0%	0.0%	○	0909
F9.10	PID differential limit range	0.00% ~ 100.00%	0.10%	○	090A
F9.11	PID setting change time	0.00 ~ 650.00s	0.00s	○	090B
F9.12	PID feedback filtering time	0.00 ~ 60.00s	0.00s	○	090C
F9.13	PID output filtering time	0.00 ~ 60.00s	0.00s	○	090D
F9.14	Proportional gain P2	0.0 ~ 1000.0	20	○	090E
F9.15	Integral time I2	0.00s ~ 10.00s	2.00s	○	090F

Function Code	Parameter Name	Setting Range	Default	Property	Add. HEX
F9.16	Differential time D2	0.000s ~ 10.000s	0.000s	○	0910
F9.17	PID parameter switchover condition	0: No switchover 1: DI terminal 2: Automatic switchover based on deviation	0	○	0911
F9.18	PID parameter switchover deviation 1	0.0% ~ F9.19	20.0%	○	0912
F9.19	PID parameter switchover deviation 2	F9.18 ~ 100.0%	80.0%	○	0913
F9.20	PID initial value	0.0% ~ 100.0%	0.0%	○	0914
F9.21	PID initial value holding time	0.00 ~ 650.00s	0.00s	○	0915
F9.22	Two output deviation forward maximum.	0.00% ~ 100.00%	1.00%	○	0916
F9.23	Two output deviation reverse maximum	0.00% ~ 100.00%	1.00%	○	0917
F9.24	PID integral property	Single-digit: Integration separation 0: Disabled 1: Enabled Ten's digit: Output to limit value 0: Continue the integral 1: Stop the integral	0	○	0918
F9.25	Detection value of PID feedback loss	0.0%: No judging feedback loss 0.1% ~ 100.0%	0.0%	○	0919
F9.26	Detection time of PID feedback loss	0.0s ~ 20.0s	0.0s	○	091A
F9.27	PID operation at stop	0: No PID operation at stop 1: PID operation at stop	0	○	091B
F9.28	PID function selection	0: Normal PID 1: Sleep PID	0	○	091C
F9.29	PID sleep threshold	0.0% ~ 100.0%	60.0%	○	091D
F9.30	PID sleep delay	0.0 ~ 3600.0s	3.0s	○	091E
F9.31	ID wake-up threshold	0.0% ~ 100.0%	20.0%	○	091F
F9.32	PID wake-up time delay	0.0 ~ 3600.0s	3.0s	○	0920
F9.33	PID Minimum output	0: F0.14 1: 0 Hz	0	●	0921
FA Group: fault and protection					
FA.00	Motor overload protection selection	0: Disabled 1: Enabled	1	○	0A00
FA.01	Motor overload protection gain	0.20 ~ 10.00	1	○	0A01

Function Code	Parameter Name	Setting Range	Default	Property	Add. HEX
FA.02	Motor overload warning coefficient	50% ~ 100%	80%	○	0A02
FA.03	Overvoltage stall gain	0 ~ 100	10	○	0A03
FA.04	Overvoltage stall protective voltage	120% ~ 150%	130%	○	0A04
FA.05	Overcurrent stall gain	0 ~ 100	Model dependent	○	0A05
FA.06	Overvoltage stall protective current	100% ~ 200%	150%	○	0A06
FA.07	Short-circuit to ground upon power-on	0: Disabled 1: Enabled	1	○	0A07
FA.08	Fault auto reset times	0 ~ 5	0	○	0A08
FA.09	DO action during fault auto reset	0: No act 1: Act	0	○	0A09
FA.10	Time interval of fault auto reset	0.1s ~ 100.0s	1.0s	○	0A0A
FA.11	Input phase loss protection	0: Disabled 1: Enabled	1	○	0A0B
FA.12	Output phase loss protection	0: Disabled 1: Enabled	1	○	0A0C
FA.13	Fault protection action selection 1	0: Free stopping 1: Stop according to the stop mode 2: Continue to run Single-digit: Motor overload (Err11) Ten's digit: Input phase loss (Err12) Hundred's digit: Output phase loss (Err13) Thousand's digit: External equipment fault (Err15) Ten thousand's digit: Communication fault (Err16)	0	○	0A0D
FA.14	Reserved	-	-	-	0A0E
FA.15	Fault protection action selection 3	0: Free stopping 1: Stop according to the stop mode 2: Continue to run Single-digit: User-defined fault 1 (Err27) Ten's digit: User-defined fault 2 (Err28) Hundred's digit: Reserved Thousand's digit: Drop (Err30) Ten thousand's digit: PID feedback loss at run time (Err31)	0	○	0A0F
FA.16	Reserved	-	-	-	0A10
FA.17	Reserved	-	-	-	0A11

Function Code	Parameter Name	Setting Range	Default	Property	Add. HEX
FA.18	Undervoltage setting	60.0% ~ 140.0%	100.00%	○	0A12
FA.19	Overvoltage setting	200.0V ~ 810.0V	810.0V	○	0A13
FA.20	Continuerunning frequency selection during failure	0: Run with the current run frequency 1: Run with the setting frequency 2: Run with the upper limit frequency 3: Run with lower limit frequency. 4: Run with standby frequency when abnormal	0	○	0A14
FA.21	Abnormal standby frequency setting	0.0% ~ 100.0%(Current target frequency)	100.00%	○	0A15
FA.22	Action selection at instantaneous power failure	0: Invalid 1: Slow down 2: Deceleration stop	0	○	0A16
FA.23	Action pause judging voltage at instantaneous power failure	80.0% ~ 100.0%	90.00%	○	0A17
FA.24	Voltage rally judging time at instantaneous power failure	0.00s ~ 100.00s	0.50s	○	0A18
FA.25	Action judging voltage at instantaneous power failure	60.0% ~ 100.0%(standard bus voltage)	80.00%	○	0A19
FA.26	Loss of loads protection options	0: Disabled 1: Enabled	0	○	0A1A
FA.27	Loss of loads detection level	0.0 ~ 100.0%	10.00%	○	0A1B
FA.28	Loss of loads detection time	0.0 ~ 60.0s	1.0s	○	0A1C
FA.29	The decimal point of the frequency in failure state	1: 1 decimal point 2: 2 decimal point Single-digit: The third fault frequency decimal point Ten's digit: The second failure frequency of the decimal point Hundred's digit: The first failure frequency of the decimal point	222	○	0A1D
FB Group: swing frequency, fixed length and count					
FB.00	Swing frequency setting mode	0: Relative to the central frequency 1: Relative to the maximum frequency	0	○	0B00
FB.01	Swing frequency amplitude	0.0% ~ 100.0%	0.00%	○	0B01
FB.02	Jump frequency amplitude	0.0% ~ 50.0%	0.00%	○	0B02

Function Code	Parameter Name	Setting Range	Default	Property	Add. HEX
FB.03	Swing frequency cycle	0.1s ~ 3000.0s	10.0s	○	0B03
FB.04	Triangular wave rising time coefficient	0.1% ~ 100.0%	50.00%	○	0B04
FB.05	Setting length	0m ~ 65535m	1000m	○	0B05
FB.06	Actual length	0m ~ 65535m	0m	○	0B06
FB.07	Number of pulses per meter	0.1 ~ 6553.5	100	○	0B07
FB.08	Set count value	1 ~ 65535	1000	○	0B08
FB.09	Designated count value	1 ~ 65535	1000	○	0B09
FC Group: communication parameters					
FC.00	Local address	1 ~ 247, 0 is broadcast address	1	○	0C00
FC.01	Baud rate	0: 300 bps 1: 600 bps 2: 1200 bps 3: 2400 bps 4: 4800 bps 5: 9600 bps 6: 19200 bps 7: 38400 bps 8: 57600 bps 9: 115200 bps	5	○	0C01
FC.02	Data format	0: No check, data format <8,N,2> 1: Even parity check, data format <8,E,1> 2: Odd Parity check, data format <8,0,1> 3: No check, data format <8,N,1>	3	○	0C02
FC.03	Response delay	0ms ~ 20ms	2	○	0C03
FC.04	Communication timeout	0.0 (invalid) 0.1s~60.0s	0	○	0C04
FC.05	Communication reading current resolution	0: 0.01A 1: 0.1A	0	○	0C05
FD Group: multi-speed instructions and simple PLC function					
FD.00	Multistage speed 0	-100.0% ~ 100.0% (F0.10)	0.00%	○	0D00
FD.01	Multistage speed 1	-100.0% ~ 100.0%	0.00%	○	0D01
FD.02	Multistage speed 2	-100.0% ~ 100.0%	0.00%	○	0D02
FD.03	Multistage speed 3	-100.0% ~ 100.0%	0.00%	○	0D03
FD.04	Multistage speed 4	-100.0% ~ 100.0%	0.00%	○	0D04
FD.05	Multistage speed 5	-100.0% ~ 100.0%	0.00%	○	0D05

Function Code	Parameter Name	Setting Range	Default	Property	Add. HEX
FD.06	Multistage speed 6	-100.0% ~ 100.0%	0.00%	○	0D06
FD.07	Multistage speed 7	-100.0% ~ 100.0%	0.00%	○	0D07
FD.08	Multistage speed 8	-100.0% ~ 100.0%	0.00%	○	0D08
FD.09	Multistage speed 9	-100.0% ~ 100.0%	0.00%	○	0D09
FD.10	Multistage speed 10	-100.0% ~ 100.0%	0.00%	○	0D0A
FD.11	Multistage speed 11	-100.0% ~ 100.0%	0.00%	○	0D0B
FD.12	Multistage speed 12	-100.0% ~ 100.0%	0.00%	○	0D0C
FD.13	Multistage speed 13	-100.0% ~ 100.0%	0.00%	○	0D0D
FD.14	Multistage speed 14	-100.0% ~ 100.0%	0.00%	○	0D0E
FD.15	Multistage speed 15	-100.0% ~ 100.0%	0.00%	○	0D0F
FD.16	Simple PLC running mode	0: Stop after the AC Drive runs one cycle 1: Keep final values after the AC Drive runs one cycle 2: Repeat after the AC Drive runs one cycle	0	○	0D10
FD.17	Simple PLC retentive selection	Single-digit: (Retentive upon power failure) 0: No 1: Yes Ten's digit: (Retentive upon stop) 0: No 1: Yes	0	○	0D11
FD.18	Running time of simple PLC reference 0	0.0s(h) ~ 6553.5s(h)	0.0s(h)	○	0D12
FD.19	Acceleration/deceleration time of simple PLC reference 0	0 ~ 3	0	○	0D13
FD.20	Running time of simple PLC reference 1	0.0s(h) ~ 6553.5s(h)	0.0s(h)	○	0D14
FD.21	Acceleration/deceleration time of simple PLC reference 1	0 ~ 3	0	○	0D15
FD.22	Running time of simple PLC reference 2	0.0s(h) ~ 6553.5s(h)	0.0s(h)	○	0D16
FD.23	Acceleration/deceleration time of simple PLC reference 2	0 ~ 3	0	○	0D17
FD.24	Running time of simple PLC reference 3	0.0s(h) ~ 6553.5s(h)	0.0s(h)	○	0D18
FD.25	Acceleration/deceleration time of simple PLC reference 3	0 ~ 3	0	○	0D19

Function Code	Parameter Name	Setting Range	Default	Property	Add. HEX
FD.26	Running time of simple PLC reference 4	0.0s(h) ~ 6553.5s(h)	0.0s(h)	○	0D1A
FD.27	Acceleration/deceleration time of simple PLC reference 4	0 ~ 3	0	○	0D1B
FD.28	Running time of simple PLC reference 5	0.0s(h) ~ 6553.5s(h)	0.0s(h)	○	0D1C
FD.29	Acceleration/deceleration time of simple PLC reference 5	0 ~ 3	0	○	0D1D
FD.30	Running time of simple PLC reference 6	0.0s(h) ~ 6553.5s(h)	0.0s(h)	○	0D1E
FD.31	Acceleration/deceleration time of simple PLC reference 6	0 ~ 3	0	○	0D1F
FD.32	Running time of simple PLC reference 7	0.0s(h) ~ 6553.5s(h)	0.0s(h)	○	0D20
FD.33	Acceleration/deceleration time of simple PLC reference 7	0 ~ 3	0	○	0D21
FD.34	Running time of simple PLC reference 8	0.0s(h) ~ 6553.5s(h)	0.0s(h)	○	0D22
FD.35	Acceleration/deceleration time of simple PLC reference 8	0 ~ 3	0	○	0D23
FD.36	Running time of simple PLC reference 9	0.0s(h) ~ 6553.5s(h)	0.0s(h)	○	0D24
FD.37	Acceleration/deceleration time of simple PLC reference 9	0 ~ 3	0	○	0D25
FD.38	Running time of simple PLC reference 10	0.0s(h) ~ 6553.5s(h)	0.0s(h)	○	0D26
FD.39	Acceleration/deceleration time of simple PLC reference 10	0 ~ 3	0	○	0D27
FD.40	Running time of simple PLC reference 11	0.0s(h) ~ 6553.5s(h)	0.0s(h)	○	0D28
FD.41	Acceleration/deceleration time of simple PLC reference 11	0 ~ 3	0	○	0D29
FD.42	Running time of simple PLC reference 12	0.0s(h) ~ 6553.5s(h)	0.0s(h)	○	0D2A

Function Code	Parameter Name	Setting Range	Default	Property	Add. HEX
FD.43	Acceleration/deceleration time of simple PLC reference 12	0 ~ 3	0	○	0D2B
FD.44	Running time of simple PLC reference 13	0.0s(h) ~ 6553.5s(h)	0.0s(h)	○	0D2C
FD.45	Acceleration/deceleration time of simple PLC reference 13	0 ~ 3	0	○	0D2D
FD.46	Running time of simple PLC reference 14	0.0s(h) ~ 6553.5s(h)	0.0s(h)	○	0D2E
FD.47	Acceleration/deceleration time of simple PLC reference 14	0 ~ 3	0	○	0D2F
FD.48	Running time of simple PLC reference 15	0.0s(h) ~ 6553.5s(h)	0.0s(h)	○	0D30
FD.49	Acceleration/deceleration time of simple PLC reference 16	0 ~ 3	0	○	0D31
FD.50	Time unit of simple PLC running	0: S (second) 1: H (hour) 2: Min (minute)	0	○	0D32
FD.51	The source of multistage speed 0	0: Set by FD.00 1: AI1 2: AI2 3: Reserved 4: Reserved 5: PID 6: Set by preset frequency (F0.08)	0	○	0D33
FE Group: function code management					
FE.00	User password	0 ~ 65535	0	○	0E00
FE.01	Fault record display times	0 ~ 15	5	○	0E01

4.2 Fault Records

Function Code	Parameter Name	Setting Range	Property	Address
E0 Group: the latest failure record				
E0.00	The latest fault type	0: No fault 1: Output short-circuit fault (Err01) 2: Overcurrent during acceleration (Err02) 3: Overcurrent during deceleration (Err03) 4: Overcurrent at constant speed (Err04) 5: Overvoltage during acceleration (Err05) 6: Overvoltage during deceleration (Err06) 7: Overvoltage at constant speed (Err07) 8: Buffer resistance overload (Err08) 9: Undervoltage (Err09) 10: AC Drive overload (Err10) 11: Motor overload (Err11) 12: Input missing phase (Err12) 13: Output missing phase (Err13) 14: Module overheating (Err14) 15: External equipment fault (Err15) 16: Communication fault (Err16) 17: Contactor fault (Err17) 18: Current detection fault (Err18) 19: Motor auto-tuning fault (Err19) 21: Data overflow (Err21) 22: On-power EEPROM check fault (Err22) 23: Short circuit to ground (Err23) 24: Reserved 25: Reserved 26: Running time arrival (Err26) 27: User-defined fault 1 28: User-defined fault 2 (Err28) 29: On-power arrival time (Err29) 30: Load drop (Err30) 31: PID feedback loss during running (Err31) 40: With-wave current limit fault (Err40) 41: Reserved	●	E000
E0.01	Frequency by the latest failure	0.0Hz~F0.10 (Maximum frequency)	●	E001
E0.02	Current by the latest failure	0.00~655.35	●	E002
E0.03	Bus voltage by the latest failure	0.0~810.0	●	E003
E0.04	Input terminal state by the latest failure	0~63	●	E004
E0.05	Output terminal state by the latest failure	0~63	●	E005
E0.06	The temperature of AC Drive by the latest failure	0~65535	●	E006
E0.07	The AC Drive state by	0~FFFF	●	E007

Function Code	Parameter Name	Setting Range	Property	Address
	the latest failure			
E0.08	Time of latest failure (timing from this on-power time)	0~65535	●	E008
E0.09	Time of the latest failure (timing from the running beginning)	0~6553.5	●	E009
E0.10	Reserved	—	●	E010
E0.11	Reserved	—	●	E011

4.3 Monitoring parameters

Function Code	Parameter Name	Min.Unit	Property	Address
D0 Group: monitoring				
D0.00	Operating frequency (Hz)	0.01Hz	●	D000
D0.01	Setting frequency (Hz)	0.01Hz	●	D001
D0.02	Bus voltage (V)	0.1V	●	D002
D0.03	Output voltage (V)	1V	●	D003
D0.04	Output current (A)	0.01A	●	D004
D0.05	Output power (kW)	0.1kW	●	D005
D0.06	Output torque (%)	0.1%	●	D006
D0.07	DI input status	1	●	D007
D0.08	DO output status	1	●	D008
D0.09	AI1 voltage (V)	0.01V	●	D009
D0.10	AI2 voltage (V)	0.01V	●	D00A
D0.11	Reserved	—	●	D00B
D0.12	Count value	1	●	D00C
D0.13	Length value	1	●	D00D
D0.14	Load speed display	1	●	D00E
D0.15	PID setting	1	●	D00F
D0.16	PID feedback	1	●	D010
D0.17	PLC stage	1	●	D011
D0.18	Reserved	0.01kHz	●	D012

Function Code	Parameter Name	Min.Unit	Property	Address
D0.19	Feedback speed	0.1Hz	⊙	D013
D0.20	Remained running time	0.1Min	⊙	D014
D0.21	AI1 voltage before correction	0.001V	⊙	D015
D0.22	AI2 voltage before correction	0.001V	⊙	D016
D0.23	Reserved	—	⊙	D017
D0.24	Linear speed	1m/Min	⊙	D018
D0.25	Current power-on time	1Min	⊙	D019
D0.26	Current running time	0.1Min	⊙	D01A
D0.27	Reserved	—	⊙	D01B
D0.28	Communication setting	0.01%	⊙	D01C
D0.29	Reserved		⊙	D01D
D0.30	Main frequency X display	0.01Hz	⊙	D01E
D0.31	Auxiliary frequency Y display	0.01Hz	⊙	D01F
D0.32	Viewing any register address value	1	⊙	D020
D0.33	Reserved		⊙	D021
D0.34	Reserved		⊙	D022
D0.35	Target torque	0.1%	⊙	D023
D0.36	Reserved		⊙	D024
D0.37	Reserved	—	⊙	D025
D0.38	Reserved		⊙	D026
D0.39	Target voltage upon V/F separation	1V	⊙	D027
D0.40	Output voltage upon V/F separation	1V	⊙	D028

Chapter 5 Communication protocol

VM1000B Series AC Drive provides RS485 communication interface and supports Modbus communication protocol. Users can achieve centralized control by computer or PLC, set AC Drive operation commands, modify or read function code parameters, read the working state and fault info of the AC Drive.

5.1 Communication control address

Function	Address definition	Data meaning	Read/Write character
Communication set value	1000H	-10000~10000 (decimal) ◆ -10000 correspond -100.00% ◆ 10000 correspond 100.00%	Read/Write
Communication control command	2000H	0001: Forward running	Write
		0002: Reverse running	
		0003: JOG forward	
		0004: JOG reverse	
		0005: Free stop	
		0006: Deceleration stop	
		0007: Fault reset	
Digital output terminal	2001H	BIT0~BIT1: Reserved	Write
		BIT2: Relay1 output control	
		BIT3: Relay2 output control	
		BIT4: FMR Output control	
		BIT5:VD0	
		BIT6~BIT9: Reserved	
Analog output AO1 control	2002H	0~7FFF correspond 0%~100%	Write
Analog output AO2 control	2003H	0~7FFF correspond 0%~100%	Write
Pulse output control	2004H	0~7FFF correspond 0%~100%	Write

Table 5-1-1 Communication control address

5.2 Parameter status address

Parameter description	Parameter address	Unit	Read/Write character
Operating frequency	1001H	0.01Hz	Read
Bus voltage	1002H	0.1V	Read
Output voltage	1003H	1V	Read
Output current	1004H	0.01A	Read
Output power	1005H	0.1kW	Read
Output torque	1006H	0.1%	Read
Running speed	1007H	0.01Hz	Read
DI Input sign	1008H	1	Read
DO Output sign	1009H	1	Read
A11 Voltage	100AH	0.01V	Read
A12 Voltage	100BH	0.01V	Read
Reserved	100CH	—	Read
Count value input	100DH	1	Read
Length value input	100EH	1	Read
Load speed	100FH	1rpm	Read
PID Setting	1010H	0.10%	Read
PID Feedback	1011H	0.10%	Read
PLC Step	1012H	1 (0~15)	Read
Reserved	1013H	—	Read
Reserved	1014H	—	Read
Remained running time	1015H	1min	Read
A11 voltage before correction	1016H	0.001V	Read
A12 voltage before correction	1017H	0.001V	Read
Reserved	1018H	—	Read
Linear speed	1019H	1m/min	Read
Current power-on time	101AH	1min	Read

Current running time	101BH	0.1min	Read
Reserved	101CH	—	Read
Communication set value	101DH	1 (-10000~10000)	Read
Reserved	101EH	—	Read
Main frequency X display	101FH	0.01Hz	Read
Auxiliary frequency Y display	1020H	0.01Hz	Read

Table 5-2-1 Parameter status address

5.3 AC Drive state and fault description

Parameter description	Parameter address	Data meaning	Read/Write character
The AC Drive state	3000H	0001: Forward running 0002: Reverse running 0003: AC Drive standby 0004: AC Drive failure 0005: AC Drive undervoltage 0006: Forward and reverse switch	Read
The AC Drive fault	8000H	0000: No fault 0001: Output short-circuit fault 0002: Overcurrent during acceleration 0003: Overcurrent during deceleration 0004: Overcurrent at constant speed 0005: Overvoltage during acceleration 0006: Overvoltage during deceleration 0007: Overvoltage at constant speed 0008: Buffer resistance overload 0009: Undervoltage 000A: AC Drive overload 000B: Motor overload 000C: Input missing phase 000D: Output missing phase 000E: Module overheating 000F: External equipment fault 0010: Communication fault 0011: Contactor fault 0012: Current detection fault 0013: Motor auto-tuning fault 0015: Parameter read and write abnormally 0016: On-power EEPROM check fault 0017: Short circuit to ground 001A: Running time arrival 001B: User-defined fault 1 001C: User-defined fault 2 001D: On-power arrival time 001E: Reserved 001F: PID feedback loss during running 0028: With-wave current limit fault (Err40) 0029: Reserved	Read
Communication fault	8001H	0000: No fault 0001: Password error 0002: Command code error 0003: CRC Check error 0004: Invalid address 0005: Invalid parameter 0006: Invalid change parameter 0007: System locked 0008: EEPROM in operation	Read

Table 5-3-1 AC Drive state and fault description

5.4 EEPROM-RAM address exchange description

When communication address in the function code table is the way of writing RAM ways, RAM memory address is the address for power-off but not saving. Under communication way, for writing the command “06H”, if the parameters shall be saved in power-off condition, it could be realized by only changing value in EEPROM. This means you shall change “0”, the highest position in RAM address, into “F”, which is to change into the way of writing EEPROM, also means to change “0XXX” into “FXXX” . Writing life span of EEPROM is generally 1 million times. Frequent changing EEPROM writing will reduce the life span.

Address change example:

Function code	Parameter Name	The RAM Address	The EEPROM Address
F0.10	Maximum frequency	000A	F00A
F0.18	Acceleration time 1	0012	F012

Table 5-4-1 Communication address change rule

Communication address of writing RAM of other parameters shall be in the similar way...

Chapter 6 Troubleshooting & countermeasures

6.1 Faults and solutions

Fault code	Fault type	Reason	Solution
Err01	Output short-circuit fault	1.Short-circuit phenomena exists in AC Drive output	1. Ask for technical service
Err02	Overcurrent during acceleration	1. The output circuit of AC Drive is grounded or short circuited. 2. The acceleration time is too short. 3. The startup operation is performed on the rotating motor. 4. The AC Drive model is of too small power.	1. Eliminate external faults. 2. Increase the acceleration time. 3. Select rotational speed tracking restart or start the motor after it stops. 4. Select the AC Drive of higher power.
Err03	Overcurrent during deceleration	1. The output circuit of AC Drive is grounded or short circuited. 2. The deceleration time is too short.	1. Eliminate external faults. 2. Increase the deceleration time.
Err04	Overcurrent at constant speed	1. The output circuit of AC Drive is grounded or short circuited. 2. The AC Drive model is of too small power.	1. Eliminate external faults. 2. Select the AC Drive of higher power.
Err05	Overvoltage during acceleration	1. Input voltage abnormal. 2. An external force drives the motor during acceleration. 3. The acceleration time is too short. 4. The braking unit and braking resistor are not installed.	1. Turn the input power to the normal range. 2. Cancel the external force. 3. Increase the acceleration time. 4. Installed the braking unit and braking resistor.
Err06	Overvoltage during deceleration	1. Input voltage abnormal. 2. An external force drives the motor during deceleration. 3. The deceleration time is too short. 4. The braking unit and braking resistor are not installed.	1. Turn the input power to the normal range. 2. Cancel the external force. 3. Increase the deceleration time. 4. Installed the braking unit and braking resistor.
Err07	Overvoltage at constant speed	1. Input voltage abnormal. 2. An external force drives the motor during deceleration.	1. Turn the input power to the normal range. 2. Cancel the external force.
Err08	Buffer resistance overload	1. The input voltage is not within the allowable range.	1. Adjust the input voltage to the allowable range.
Err09	Undervoltage	1. Instantaneous power failure occurs on the input supply. 2. The input voltage is not within the normal range. 3. The AC Drive has an	1. Reset the fault. 2. Adjust the input voltage to normal range. 3. Looking for technical service.

Fault code	Fault type	Reason	Solution
		abnormality.	
Err10	AC Drive overload	1. The load is too heavy or locked rotor occurs on motor. 2. The AC Drive model is of too small power.	1. Reduce the load and check the motor. 2. Select the AC Drive of higher power.
Err11	Motor overload	1. Motor overload protection parameters are not suitable. (FA.01-FA.02). 2. The AC Drive model is of too small power.	1. Set this parameter correctly. 2. Reduce the load and check the motor.
Err12	Input missing phase	1. The input three-phase power is abnormal. 2. The AC Drive has an abnormality.	1. Check input power. 2. Ask for technical service.
Err13	Output missing phase	1. Motor failure. 2. The cable connecting the AC Drive and motor is faulty. 3. The AC Drive's three-phase outputs are unbalanced when the motor is running.	1. Check if the motor is faulty. 2. Eliminate external faults. 3. Check whether the motor three-phase winding is normal.
Err14	Module overheating	1. The ambient temperature is too high. 2. The air filter is blocked. 3. The fan is damaged. 4. The IGBT is damaged.	1. Lower the ambient temperature. 2. Clean the air filter. 3. Replace the fan. 4. Ask for technical service.
Err15	External equipment fault	1. External fault signal is input DI terminal or VDI function.	1. Check the input DI terminal or VDI function.
Err16	Communication fault	1. The PC is in abnormal state. 2. The communication cable is faulty. 3. The communication parameters of FC group are set improperly.	1. Check the cabling of the PC. 2. Check the communication cabling. 3. Set the communication parameters properly.
Err17	Contacting fault	The contactor is not closed	1. Ask for technical service.
Err18	Current detection fault	1. Current detection circuit is abnormal. 2. Control circuit is abnormal.	1. Ask for technical service.
Err19	Motor auto-tuning fault	1. The motor parameters are not set according to nameplate. 2. The motor auto-tuning times out.	1. Set the motor parameters according to the nameplate properly. 2. Check the cable connecting the AC Drive and the motor.
Err21	Data overflow	1. The control board is abnormal.	1. Ask for technical service.
Err22	On-power EEPROM check fault	1. The EEPROM chip is damaged.	1. Ask for technical service.
Err23	Short circuit to ground	1. The motor is short circuited to the ground. 2. The drive board is abnormal.	1. Replace the cable or motor. 2. Ask for technical service.

Fault code	Fault type	Reason	Solution
Err26	Running time arrival	1. The running time reaches the setting value.	1. Clear the record through the parameter initialization function.
Err27	User-defined fault 1	1. The user-defined fault 1 signal is input DI terminal.	1. Check the input DI terminal or the function of user-defined fault 1.
Err28	User-defined fault 2	1. The user-defined fault 2 signal is input DI terminal	1. Check the input DI terminal or the function of user-defined fault 2.
Err29	On-power arrival time	1. The accumulative power-on time reaches the setting value.	1. Clear the record through the parameter initialization function.
Err31	PID feedback loss during running	1. PID feedback signal is abnormal. 2. PID actual feedback is less than feedback loss detection.	1. Check the PID feedback signal. 2. Correctly set parameters about PID.
Err40	With-wave current limit fault	1. The load is too heavy or lockedrotor occurs on the motor. 2. The AC Drive model is of too small power.	1. Reduce the load and check the motor. 2. Select the AC Drive of higher power.
E098/ E099	Internal communication failure	1. The line of keypad communication is abnormal. 2. Control board and keypad is abnormal.	1. Replace the keypad communication line. 2. Ask for technical service.

Table 6-1-1 Faults and solutions

6.2 Common faults and solutions

SN	Fault	Possible causes	Solutions
1	No display at power-on state	<ol style="list-style-type: none"> 1. The input power of AC Drive is abnormal. 2. The control board has a bad contact with cable that is connected to the keypad. 3. The AC Drive is abnormal. 	<ol style="list-style-type: none"> 1. Check the input power. 2. Re-connect the cable. 3. Ask for technical service.
2	The motor does not rotate after the AC Drive runs.	<ol style="list-style-type: none"> 1. The motor is damaged. 2. The motor cables is abnormal. 3. The cable between the drive board and control board is in poor contact. 4. The AC Drive is abnormal. 	<ol style="list-style-type: none"> 1. Replay the motor. 2. Ensure the cable between the AC Drive and the motor is normal. 3. Check the cable between the drive board and control board. 4. Ask for technical service.
3	DI terminals are disabled.	<ol style="list-style-type: none"> 1. The parameters are set incorrectly. 2. The external signal is incorrect. 3. The control board is abnormal. 	<ol style="list-style-type: none"> 1. Check and reset the parameters in group F5. 2. Re-connect the external signal cables. 3. Ask for technical service.
4	AC Drive interference	<ol style="list-style-type: none"> 1. Carrier frequency setting is not suitable. 2. The grounding method of the AC Drive and the motor is incorrect. 3. The wire between the AC Drive and the motor is too long. 	<ol style="list-style-type: none"> 1. Reduce the carrier frequency (F0.16) 2. The AC Drive and the motor are effectively grounded and separated from the ground of the peripheral device. 3. Install out reactor or reduce wire distance.
5	Motor noise is too loud.	<ol style="list-style-type: none"> 1. Motor damage or mechanical failure. 2. Carrier frequency setting is too small. 	<ol style="list-style-type: none"> 1. Replace the motor or clear the mechanical fault. 2. Increase the carrier frequency appropriately.
6	Switch trip	<ol style="list-style-type: none"> 1. Installed a leakage switch or an air switch overload. 2. The input power of AC Drive is abnormal. 3. The AC Drive is damaged. 	<ol style="list-style-type: none"> 1. Replay the leakage switch or replay the larfer capacity air switch. 2. Eliminate whether the input power is shorted. 3. Ask for technical service.

Table 6-2-1 Common faults and solutions

Chapter 7 Contact SAJ

Guangzhou Sanjing Electric Co., Ltd.

SAJ Innovation Park, No.9, Lizhishan Road, Science City, Guangzhou High-tech Zone,
Guangdong, P.R.China.

Postcode : 510663

Web. : [http : //www.saj-electric.com](http://www.saj-electric.com)

Technical Support & Service

Fax : +86 20 6660 8589

E-mail : service.drive01@saj-electric.com

International Sales

Tel : +86 20 6660 0069

Fax : +86 20 6660 8589

E-mail : sales.drive01@saj-electric.com , sales.drive02@saj-electric.com

Chapter 8 Warranty Policy

Thank you for using SAJ products.

To ensure the high quality service for the products you bought from SAJ, please read the following items carefully:

1.1 Standard warranty period

Standard warranty period of VM1000B series general purpose AC Drive is 18 months from the date of delivery from factory, referring to the barcode on the AC Drive body.

1.2 Warranty scope

During the warranty period, in case there is any fault in the product as long as it's used normally as required, SAJ will provides you free product maintenance service if you offers the maintenance card.

1.3 Conditions as below will be out of the warranty scope

1. Damage to the product due to incorrect maintenance, on-site incidents or natural disasters, etc.;
2. Damage to the product by unpermitted dismantling and re-assembling or re-structuring the product;
3. SN has been changed, missed or wrong SN;
4. Damage to the product caused by incorrect use by disobeying the user manual or by human factors;
5. No warranty card is sent back to aftersales service center of SAJ.

Product warranty Card

Customer info.	Company name:	
	Company address:	
	Contact:	Tel.:
	Fax:	Zip code:
Product info.	Product model:	SN code:
	Buying date:	Fault date:
	Motor power:	Application situation:
Fault info.	Fault description:	
	Signature:	Date:

Guangzhou Sanjing Electric Co., Ltd.

Zip : 510663

Tel. : +86 20 6660 8588

Fax : +86 20 6660 8589

Web. : <http://www.saj-electric.com>

Add. : SAJ Innovation Park, No.9, Lizhishan Road, Science City, Guangzhou High-tech Zone,
Guangdong, P.R.China.

Due to continuous improvement of products , technical parameters in this manual are modified without prior notice.